



SPD

SURGE PROTECTIVE DEVICE

써지 보호 장치



써지 보호 장치

SPD

특징

1. 콤팩트한 형태로 써지 내량(耐量)이 큼니다.
2. 분전함 등에 직접 설치 가능합니다.
3. 급준(急峻)한 써지에 대해서 동작 지연 현상이 없으며 응답성이 우수합니다.
4. 확실한 보호 효과를 얻기 위해 제한 전압이 낮습니다.
5. 과전(過電)수명은 정격을 초과하지 않는 써지입니다.

용도

1. 써지 내량.
2. 철도 신호 장치 보호.
3. 방송 통신 중계소 보호.
4. 수도 시설 등의 써지 대책.
5. 통신 계측, 제어 장치 보호.
6. 배전선 자동 제어 장치 보호.
7. 에스컬레이터, 엘리베이터 제어반 보호.
8. 입력 측 저압수, 배전함 메인 인입 전원용에 사용.
9. UPS 입출력, CCTV, DCS, PLC, SCADA.
10. VMS 전광판, SERVICE ENTRANCE.
11. 철도, 지하철 방송국, 통신 기지국에 사용.
12. 공업용 기계, 산업용 컴퓨터 패널에 사용.
13. 울타리 감지 시스템 전원에 사용.
14. 농장, 백화점, 운동장, 은행, 병원, 제조 사업장, 박물관, 전신 전화국, 정유 공장, 주유소, 화학공장에 사용.
15. 태양광발전설비, 원자력발전설비, 풍력발전설비 보호.

Characteristics

1. As the compact size, it is endured big surge.
2. Can be directly installed at the distribution panel.
3. Excellent response without delay in operation to abrupt surge.
4. Low clamping voltage to get definite protection effects.
5. Service life is not valid in excessive surge.

Use

1. Endurance of surge.
2. Protect railway signal device.
3. Protect the broadcasting relay station.
4. Lightning surge measure for water facility.
5. Protect communication Instrumentation and controlling device.
6. Protect automatic control device of distributioncord.
7. Escalator, Elevator control panel protection.
8. Input low voltage, Distributing box use in the main incoming power supply.
9. UPS input/out put, CCTV, DCS, PLC, SCADA.
10. VMS electronic display, SERVICE ENTERANCE.
11. Used in train, Subway network, Communication base stations.
12. Used in manufacturing machine, Industrial computer panel.
13. Fence detection system power.
14. Use in farm, eartment store, play grounds, bank, hospital, manufacturing plant, Museum, telegraph telephone company, oil refinery plant, petrol station, chemical plants, nuclear powered plants.
15. Solar power plant, nuclear power plant, wind power plant.

적용 / Application

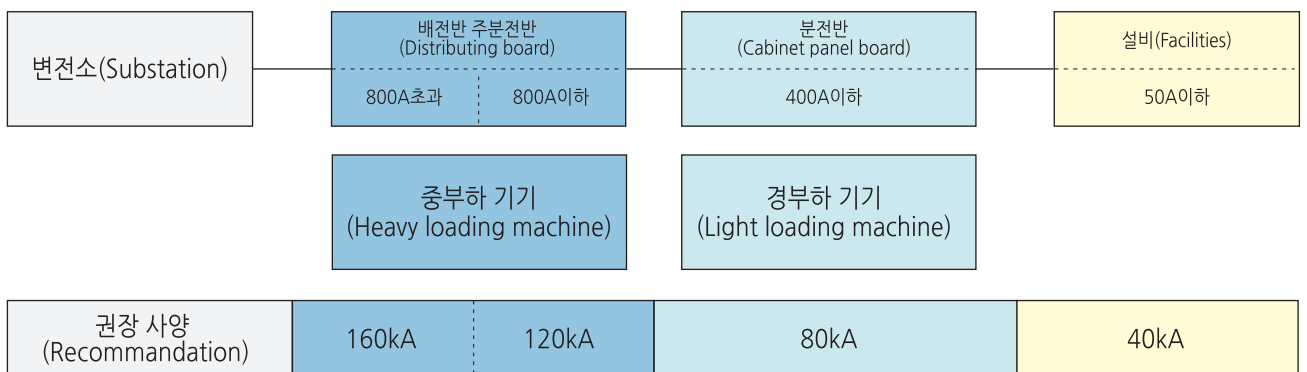



써지 보호 장치

SPD

■ 사용환경

- 사용온도 : -50℃~+85℃
- 저장온도 : -50℃~+125℃
- 습도 : 85%

■ 사용상의 주의사항

피뢰기가 정격에 초과하지 않는 써지가 침입 했을 때 단락 또는 파괴의 위험이 있으므로 다음과 같은 대책을 추천합니다.

- 피뢰기는 과전류 보호장치 A (브레커, 누전차단기, 퓨즈 기타 등) 보다 가까운 기기측에 설치해서 피뢰기가 단락시에는 신속하게 전원에서부터 분리시켜 주십시오.
- A에 과전류보호 장치를 설치할 수 없을 때에는 B에 설치해 주십시오.

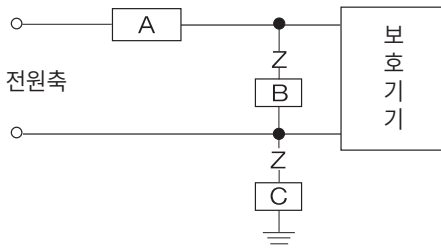

- 선 - 대지간 피뢰기가 기기케이스에 접지되었을 때 충분히 낮은 접지 저항을 얻을 수 없을 때는 A에 누전 차단기를 사용하거나 C 열반응성 온도퓨즈를 설치해 주십시오. 직사광선이나 발열체 근방에 사용할 때는 정격온도 사용 범위 내에 있는지를 확인하고 사용해 주십시오.
- 먼지나 쇳가루, 비와 이슬이 내리는 곳, 염해 오염의 우려가 있는 곳에 부득이 사용할 경우에는 보호용기 안에 넣어서 사용해 주십시오. (보호 용기를 사용할 것.)
- 피뢰기 결선용으로는 600V 비닐절연전선(IV선), 2mm² 또는 동등 이상의 것을 사용해 주십시오. (접지선은 5.5mm² 이상)
- 피뢰기 결선은 되도록 짧고 직선적으로 해주십시오.
- 전기시설 유도뇌 써지 대책용으로는 써지 내량 20,000A를 사용해 주십시오.

■ Usable condition

- Use temperature : -50℃~+85℃
- Place temperature : -50℃~+125℃
- Humidity : 85%

■ Instructions for use

We recommend the following measures since there is a risk of short or destruction when surge substantially exceeding the rating penetrates into the arrester.

- Install the arrester closer to the device than the overcurrent protection device A (breaker, leakage circuit breaker fuse, etc.) and immediately separate it from the power when it is shorted.
- Install the overcurrent protection device at B if it cannot be installed at A.

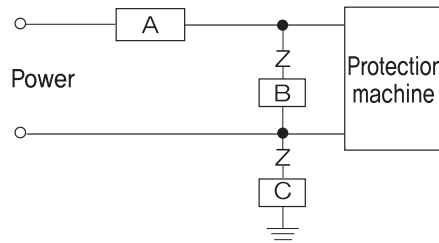

- Use leakage circuit breaker at A or install the C heat-response temperature fuse if the arrester is grounded on the device case or fully low earth resistance cannot be obtained. Check whether it is within the usage scope of rating temperature when using it near direct sunlight or heat element.
- Pit in the protection cover when you must use it in the place with dust, iron dust, exposed to rain or dew or likely to have problem of salt pollution. (Use protection cover)
- Use 600V vinyl resistance cord(IV cord), 2mm² or equivalent for wiring of arrester. (Over 5.5mm² in case of earth line)
- Wiring of arrester should be as straight and short as possible.
- Use the arrester with surge endurance of 20,000A for the measurement of electricity facility induction lightning surge.

- 오일 킬러 OIL KILLER
- 인터페이스 커버 INTERFACE COVER
- 정류기 POWER CONVERTOR
- 역결상 계전기 PHASE MONITORING RELAY
- 풋 스위치 FOOT SWITCH
- 푸쉬 버튼 스위치 PUSH BUTTON SWITCH
- 코드 스위치 CODE SWITCH
- 노브 KNOB
- 로타리 스위치 ROTARY SWITCH
- 써지 보호 장치 SURGE PROTECTIVE DEVICE**
- 스파크 킬러 SPARK KILLER
- LED 인디케이터 LED INDICATOR
- 노 퓨즈 브레카 핸들 N.F.B HANDLE
- 케이블 그랜드 CABLE GLAND
- 팬 커버 FAN COVER
- 힌지/록커/키 HINGE/LOCKER/KEY
- 로드메타·알피엠메타 LOAD METER·RPM METER
- 기타 품목 THE OTHER PRODUCTS

서지 보호 장치

SPD

KBL Type 사용상의 주의사항

1. SPD 설치 시 전원을 차단 하십시오.
2. SPD 제품은 전선의 길이를 짧게 설치할수록 보호 성능이 우수해 집니다.
3. 분전함, UPS, AVR 등 보호 대상 장비의 전압과 접지선을 확인하고 가능한 장비 주변 적합한 곳에 설치하십시오.
4. 작업 완료시 전원을 투입 하십시오.
5. 전원 투입시 LAMP가 점등되면 정상입니다.
(만약 표시등이 점등되지 않을시 차단기 전원을 내린 후 다시 한 번 전선의 연결 상태를 확인하여 주십시오.)

KBL Type Instructions for use

1. Turn off the power when SPD is installed.
2. As the shorter length of wire, better the protective performance.
3. Please check Distributing box, UPS, AVR protection equipment's voltage and ground cable and please install as soon as possible where it needed.
4. Once the installment is finished, turn on the power.
5. Lamp is light up when power on, the installment is done properly. (If the status light didn't turn on, please lower crossing gate to check length of wire connection.)

회로도 / Circuit

K Type - 2Y

(단상전원접지형 / Single phase+E)

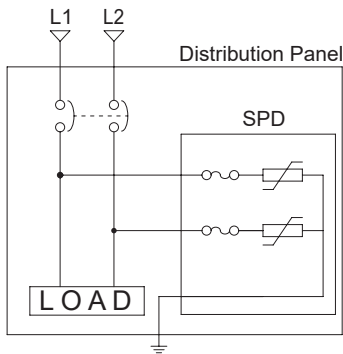

K Type - 3Y

(삼상전원접지형 / Three phase+E)

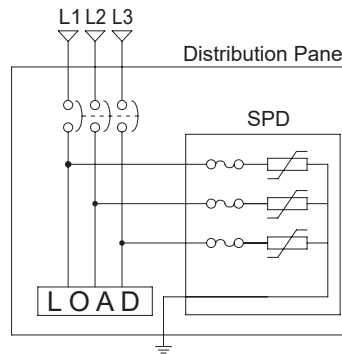

K Type - 4Y

(삼상전원N접지형 / Three phase+N+E)

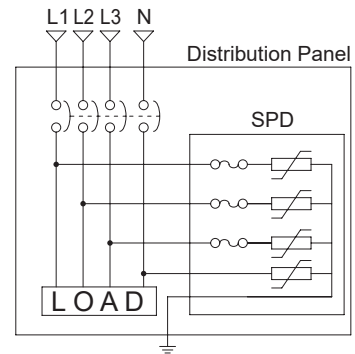

KBL Type - 2Y

(단상전원접지형 / Single phase+E)

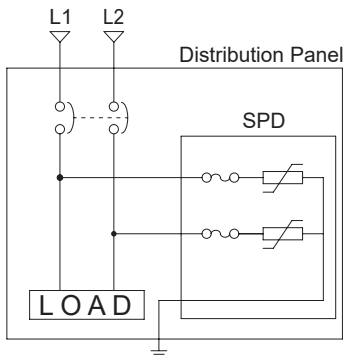

KBL Type - 3Y

(삼상전원접지형 / Three phase+E)

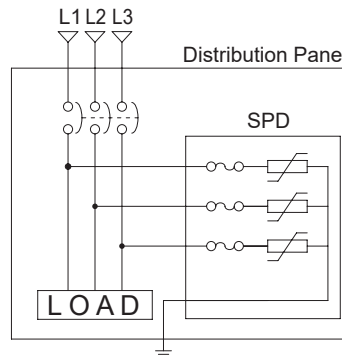

KBL Type - 4Y

(삼상전원N접지형 / Three phase+N+E)

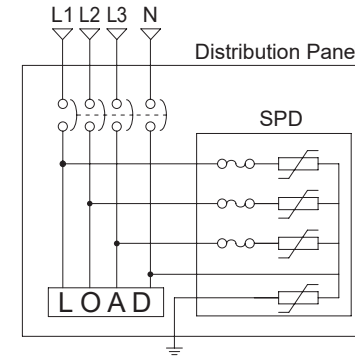



써지 보호 장치

SPD

! 안전을 위한 주의 사항 / Attention list for safety

경 고

1. 인명사고 및 막대한 재산상의 피해가 우려되는 기기 등에 사용할 경우에는 반드시 2중으로 안전장치를 부착한 후에 사용하십시오.
2. 반드시 패널에 취부하여 사용 하십시오.
감전, 오작동, 고장의 원인이 됩니다.
3. 감전방지 및 기기 고장 방지를 위하여 모든 배선이 종료될 때까지 전원을 투입하지 마십시오.
4. 지정한 성격 이외로 사용시에는 상해를 입거나 재산상의 손실이 발생 할 수 있으므로 주의하여 주십시오.
5. 본 기기의 탈착은 전원을 OFF 한 후 조치하십시오.
감전, 오작동, 고장의 원인이 됩니다.
6. 통전 중에 본 기기를 분해하거나 단자에 접촉하지 마십시오.
감전, 오작동의 위험이 있습니다.

주 의

1. 주문하신 사양과 일치 하는지 확인 하십시오.
2. 실외에서 사용하지 마십시오.
3. 부식성 가스(특히 유해가스, 암모니아 등), 가연성 가스가 발생하지 않는 장소에서 사용하십시오.
4. 물이 들어 갔을 때에는 누전, 화재의 위험성이 있으므로 필히 점검을 하시길 바랍니다.
5. 제품의 품질 향상을 위하여 부품 사양 및 디자인이 예고없이 변경될 수 있습니다.

Warning

1. When it use in a machine that might cause accidents of worker or enormous property damage, it should be used after the double safety device is attached.
2. In any case, it should be used while being attached on the panel. It might cause electric shock or malfunctioning
3. In order to prevent receiving electric shock and malfunctioning of the machine, do not supply power until all the wiring is completed and ended.
4. If it is used with the voltage other than the designated one, it might cause injury for human and property damage.
5. To separate the product, turn off the power supply first. It might cause electric shock, malfunctioning or breakdown.
6. Do not disassemble, process, remedy or repair this product in any case, because it might cause malfunctioning.

Attention

1. Make sure whether it is identical with the specification you have ordered.
2. Do not use it outside.
3. Do not use it in a place, where corrosive gas (especially, harmful gas, ammonia, etc.) and inflammable gases are generated.
4. In case of contacting water, make sure it is thoroughly inspected before use in order to prevent leakage of electricity or fire.
5. The specifications (colors and parts of design, etc.) are subject to change without prior notice for quality improvement of the product.

오일 킬러
OIL KILLER

인터페이스 커버
INTERFACE COVER

정류기
POWER CONVERTOR

역결상 계전기
PHASE MONITORING RELAY

풋 스위치
FOOT SWITCH

푸쉬 버튼 스위치
PUSH BUTTON SWITCH

코드 스위치
CODE SWITCH

노브
KNOB

로타리 스위치
ROTARY SWITCH

써지 보호 장치
SURGE PROTECTIVE DEVICE

스파크 킬러
SPARK KILLER

LED 인디케이터
LED INDICATOR

노 휴즈 브레카 핸들
N.F.B HANDLE

케이블 그랜드
CABLE GLAND

팬 커버
FAN COVER

힌지/록커/키
HINGE/LOCKER/KEY

로드메타·알피엠메타
LOAD METER·RPM METER

기타 품목
THE OTHER PRODUCTS

서지 보호 장치

SPD

사 양 / Specification

단상형 / Single phase type

Parts No.	Maximum continuous operating voltage(Uc)		Energy 10/1,000 μs (J)	Rated Wattage (w)	Withstanding Surge Current 8/20 μs 1 Time (A)	Nominal voltage at 1mA(DC) current (V)	Maximum clamping voltage (8/20μs) VC _{100A} (V)	kA			
	AC(rms) (V)	DC (V)									
K20E390	25	31	14.6	0.2	3,000	39(35~43)	* 77	3kA			
K20E560	35	45	21			56(50~62)	* 110				
K20E680	40	56	25.5			68(61~75)	* 135				
K20E820	50	65	30.8	1.0	10,000	82(74~90)	135	10kA			
K20E271	175	225	101.3			270(243~297)	455				
K20E471	300	385	176.3			470(423~517)	775				
K20E681	420	560	232.6			680(612~748)	1,120				
K20E821	510	670	246			820(738~902)	1,355				
K20E102	625	825	300			1,000(900~1,100)	1,650				
K20E152	900	1,220	449			1,500(1,350~1,650)	2,475				
K20E182	1,000	1,465	540			1,800(1,620~1,980)	2,970				
K25E271	175	225	170			1.0	15,000		270(243~297)	455	15kA
K25E471	300	385	225						470(423~517)	775	
K25E681	420	560	250	680(612~748)	1,120						
K25E821	510	670	300	820(738~902)	1,355						
K25E102	625	825	375	1,000(900~1,100)	1,650						
K25E152	900	1,220	500	1,500(1,350~1,650)	2,475						
K25E182	1,000	1,465	700	1,800(1,620~1,980)	2,970						
K32E201	130	170	210	1.2	20,000	200(185~225)	340	20kA			
K32E271	175	225	255			270(243~297)	455				
K32E471	300	385	405			470(423~517)	775				
K32E681	420	560	450			680(612~748)	1,120				
K32E821	510	670	545			820(738~902)	1,355				
K32E102	625	825	620			1,000(900~1,100)	1,650				
K32E152	900	1,220	780			1,500(1,350~1,650)	2,475				
K32E182	1,000	1,465	850			1,800(1,620~1,980)	2,970				
K40E201	130	170	340	1.4	40,000	200(185~225)	340	40kA			
K40E271	175	225	340			270(243~297)	455				
K40E471	300	385	505			471(423~517)	775				
K40E681	420	560	560			680(612~748)	1,120				
K40E821	510	670	680			820(738~902)	1,355				
K40E102	625	825	780			1,000(900~1,100)	1,650				
K40E152	900	1,220	900			1,500(1,350~1,650)	2,475				
K40E182	1,000	1,465	1,080			1,800(1,620~1,980)	2,970				
K53E201	130	170	330	1.6	70,000	200(185~225)	340	70kA			
K53E271	175	225	430			270(243~297)	455				
K53E471	300	385	640			470(423~517)	775				
K53E681	420	560	710			680(612~748)	1,120				
K53E821	510	670	860			820(738~902)	1,355				
K53E102	625	825	990			1,000(900~1,100)	1,650				
K53E152	900	1,220	1,140			1,500(1,350~1,650)	2,475				
K53E182	1,000	1,465	1,370			1,800(1,620~1,980)	2,970				

* 39V~68V의 최대 제한 전압은 전류 25A에서 측정된 값입니다. (Maximum clamping voltage from 39V to 68V is tested with current 25A.)

※ DC 전용의 단상형은 단상 전원 접지형(태양열)으로만 주문 가능합니다. (DC is applicable for Single phase+E only.)



써지 보호 장치

SPD

단상 채널형 / Single phase channel type

Parts No.	Maximum continuous operating voltage		Energy 10/1,000 μ s(V)	Rated Wattage (w)	Withstanding Surge Current 8/20 μ s 1Time(A)	Nominal voltage at 1mA(DC) current (V)	Maximum Clamping voltage (8/20 μ s) V _{100A} (V)	kA
	AC(rms)(V)	DC(V)						
KCL15E471	300	385	148	0.6	6,000	470(423~517)	775	6kA
KCL20E471	300	385	247	1.0	10,000	470(423~517)	775	10kA
KCL20E821	510	670	344			820(738~902)	1,355	
KCL20E102	625	825	420			1,000(900~1,100)	1,650	
KCL25E471	300	385	315	1.0	15,000	470(423~517)	775	15kA
KCL25E821	510	670	420			820(738~902)	1,355	
KCL25E102	625	825	525			1,000(900~1,100)	1,650	
KCL32E471	300	385	567	1.2	20,000	470(423~517)	775	20kA
KCL32E821	510	670	763			820(738~902)	1,355	
KCL32E102	625	825	868			1,000(900~1,100)	1,650	
KCL40E471	300	385	707	1.4	40,000	470(423~517)	775	40kA
KCL40E821	510	670	952			820(738~902)	1,355	
KCL40E102	625	825	1,092			1,000(900~1,100)	1,650	

※ DC 전용의 단상형은 단상 전원 접지형(태양열)으로만 주문 가능합니다. (DC is applicable for Single phase+E only.)

단상 전원 접지형 / Single phase + E type

Parts No.	Withstanding Surge Current (8/20 μ s)	Rated system voltage	Maximum continuous operating voltage	Voltage protection level
	1Time(A)	¹ U _o	² U _c	³ U _p
KC10-120V2Y	10kA	1P 120V 2W	175V	2.5kV
KC10-220V2Y	10kA	1P 220V 2W	300V	
KC10-380V2Y	10kA	1P 380V 2W	510V	
KC10-440V2Y	10kA	1P 440V 2W	625V	
KC15-120V2Y	15kA	1P 120V 2W	175V	
KC15-220V2Y	15kA	1P 220V 2W	300V	
KC15-380V2Y	15kA	1P 380V 2W	510V	
KC15-440V2Y	15kA	1P 440V 2W	625V	
K20-120V2Y	20kA	1P 120V 2W	175V	
K20-220V2Y	20kA	1P 220V 2W	300V	
K20-380V2Y	20kA	1P 380V 2W	510V	
K20-440V2Y	20kA	1P 440V 2W	625V	
K40-120V2Y	40kA	1P 120V 2W	175V	
K40-220V2Y	40kA	1P 220V 2W	300V	
K40-380V2Y	40kA	1P 380V 2W	510V	
K40-440V2Y	40kA	1P 440V 2W	625V	
K70-120V2Y	70kA	1P 120V 2W	175V	
K70-220V2Y	70kA	1P 220V 2W	300V	
K70-380V2Y	70kA	1P 380V 2W	510V	
K70-440V2Y	70kA	1P 440V 2W	550V	
K80-120V2Y	80kA	1P 120V 2W	175V	
K80-220V2Y	80kA	1P 220V 2W	300V	
K80-380V2Y	80kA	1P 380V 2W	510V	
K80-440V2Y	80kA	1P 440V 2W	550V	
KL10-120V2Y	10kA	1P 120V 2W	175V	
KL10-220V2Y	10kA	1P 220V 2W	300V	
KL10-380V2Y	10kA	1P 380V 2W	510V	
KL10-440V2Y	10kA	1P 440V 2W	625V	
KL15-120V2Y	15kA	1P 120V 2W	175V	
KL15-220V2Y	15kA	1P 220V 2W	300V	
KL15-380V2Y	15kA	1P 380V 2W	510V	
KL15-440V2Y	15kA	1P 440V 2W	625V	
KEB10-220V2Y	10kA	1P 220V 2W	300V	
KEB10-380V2Y	10kA	1P 380V 2W	510V	
KEB10-440V2Y	10kA	1P 440V 2W	625V	
KES10-220V2Y	10kA	1P 220V 2W	300V	
KES10-380V2Y	10kA	1P 380V 2W	510V	
KES10-440V2Y	10kA	1P 440V 2W	625V	

*440V의 제품은 주문 사양입니다. (440V products is on demand.)

- 오일 킬러
OIL KILLER
- 인터페이스 커버
INTERFACE COVER
- 정류기
POWER CONVERTOR
- 역결상 계전기
PHASE MONITORING RELAY
- 풋 스위치
FOOT SWITCH
- 푸쉬 버튼 스위치
PUSH BUTTON SWITCH
- 코드 스위치
CODE SWITCH
- 노브
KNOB
- 로타리 스위치
ROTARY SWITCH
- 써지 보호 장치
SURGE PROTECTIVE DEVICE**
- 스파크 킬러
SPARK KILLER
- LED 인디케이터
LED INDICATOR
- 노 휴즈 브레카 핸들
N.F.B HANDLE
- 케이블 그랜드
CABLE GLAND
- 팬 커버
FAN COVER
- 힌지/록커/키
HINGE/LOCKER/KEY
- 로드메타·알피엠메타
LOAD METER·RPM METER
- 기타 품목
THE OTHER PRODUCTS

써지 보호 장치

SPD

Parts No.	Withstanding Surge Current (8/20 μ s)	Rated system voltage	Maximum continuous operating voltage	Voltage protection level
	¹ ITime(A)	¹ Uo	² Uc	³ Up
KBL20-220V2Y	20kA	1P 220V 2W	300V	2.5kV
KBL20-380V2Y	20kA	1P 380V 2W	510V	
KBL20-440V2Y	20kA	1P 440V 2W	625V	
KBL40-220V2Y	40kA	1P 220V 2W	300V	
KBL40-380V2Y	40kA	1P 380V 2W	510V	
KBL40-440V2Y	40kA	1P 440V 2W	550V	
KBL70-220V2Y	70kA	1P 220V 2W	300V	
KBL70-380V2Y	70kA	1P 380V 2W	510V	
KBL70-440V2Y	70kA	1P 440V 2W	550V	
KBL80-220V2Y	80kA	1P 220V 2W	300V	
KBL80-380V2Y	80kA	1P 380V 2W	510V	
KBL80-440V2Y	80kA	1P 440V 2W	550V	

삼상 전원 접지형 / Three phase + E type

Parts No.	Withstanding Surge Current (8/20 μ s)	Rated system voltage	Maximum continuous operating voltage	Voltage protection level
	¹ ITime(A)	¹ Uo	² Uc	³ Up
KC10-220V3Y	10kA	3P 220V 3W	300V	2.5kV
KC10-380V3Y	10kA	3P 380V 3W	510V	
KC10-440V3Y	10kA	3P 440V 3W	625V	
KC15-220V3Y	15kA	3P 220V 3W	300V	
KC15-380V3Y	15kA	3P 380V 3W	510V	
KC15-440V3Y	15kA	3P 440V 3W	625V	
K20-220V3Y	20kA	3P 220V 3W	300V	
K20-380V3Y	20kA	3P 380V 3W	510V	
K20-440V3Y	20kA	3P 440V 3W	625V	
K40-220V3Y	40kA	3P 220V 3W	300V	
K40-380V3Y	40kA	3P 380V 3W	510V	
K40-440V3Y	40kA	3P 440V 3W	625V	
K70-220V3Y	70kA	3P 220V 3W	300V	
K70-380V3Y	70kA	3P 380V 3W	510V	
K70-440V3Y	70kA	3P 440V 3W	550V	
K80-220V3Y	80kA	3P 220V 3W	300V	
K80-380V3Y	80kA	3P 380V 3W	510V	
K80-440V3Y	80kA	3P 440V 3W	550V	
K120-220V3Y	120kA	3P 220V 3W	300V	
K120-380V3Y	120kA	3P 380V 3W	510V	
K120-440V3Y	120kA	3P 440V 3W	550V	
K160-220V3Y	160kA	3P 220V 3W	300V	
K160-380V3Y	160kA	3P 380V 3W	510V	
K160-440V3Y	160kA	3P 440V 3W	550V	
KBL40-220V3Y	40kA	3P 220V 3W	300V	
KBL40-380V3Y	40kA	3P 380V 3W	510V	
KBL40-440V3Y	40kA	3P 440V 3W	550V	
KBL70-220V3Y	70kA	3P 220V 3W	300V	
KBL70-380V3Y	70kA	3P 380V 3W	510V	
KBL70-440V3Y	70kA	3P 440V 3W	550V	
KBL80-220V3Y	80kA	3P 220V 3W	300V	
KBL80-380V3Y	80kA	3P 380V 3W	510V	
KBL80-440V3Y	80kA	3P 440V 3W	550V	
KBL120-220V3Y	120kA	3P 220V 3W	300V	
KBL120-380V3Y	120kA	3P 380V 3W	510V	
KBL120-440V3Y	120kA	3P 440V 3W	550V	
KBL160-220V3Y	160kA	3P 220V 3W	300V	
KBL160-380V3Y	160kA	3P 380V 3W	510V	
KBL160-440V3Y	160kA	3P 440V 3W	550V	

*440V의 제품은 주문 사양입니다. (440V products is on demand.)

써지 보호 장치

SPD

삼상 전원 N 접지형 / Three phase + N + E type

Parts No.	Withstanding Surge Current (8/20 μ s)	¹ U _o	² U _c	³ U _p
	1Time(A)			
K10-380V4Y	10kA	3P 380V 4W	510V	2.5kV
K15-380V4Y	15kA	3P 380V 4W	510V	
K20-380V4Y	20kA	3P 380V 4W	510V	
K40-380V4Y	40kA	3P 380V 4W	510V	
K70-380V4Y	70kA	3P 380V 4W	320V	
K80-380V4Y	80kA	3P 380V 4W	320V	
K120-380V4Y	120kA	3P 380V 4W	320V	
K160-380V4Y	160kA	3P 380V 4W	320V	
KBL40-380V4Y	40kA	3P 380V 4W	320V	
KBL70-380V4Y	70kA	3P 380V 4W	320V	
KBL80-380V4Y	80kA	3P 380V 4W	320V	
KBL120-380V4Y	120kA	3P 380V 4W	320V	
KBL160-380V4Y	160kA	3P 380V 4W	320V	
KSP20-380V4Y	20kA	3P 380V 4W	385V	1.5kV
KSP40-380V4Y	40kA	3P 380V 4W	385V	2.0kV
KSP100-380V4Y	100kA	3P 380V 4W	385V	3.2kV

¹U_o : 공칭교류전압 ²U_c : 최대연속전압 ³U_p : 전압보호레벨

¹U_o : Rated system ²U_c : Maximum continuous operating voltage ³U_p : Voltage protection level

K, KBL, KSP 공통사양 (K, KBL, KSP Common specifications)

K Type



KBL Type



KSP Type



Operation Environment	Operating frequency	Mounting method	Operating LED lamp
-40 ~ + 75 °C	50/60 Hz	M4 Screw x 4	정상 동작 : 녹색 LED 점등 Normal operating : Green LED lights up
			비정상 / 사고 후 : 녹색 LED 소등 Abnormal / accident after : Green LED lights off

오일 킬러
OIL KILLER

인터페이스 커버
INTERFACE COVER

정류기
POWER CONVERTOR

역-결상 계전기
PHASE MONITORING RELAY

풋 스위치
FOOT SWITCH

푸쉬 버튼 스위치
PUSH BUTTON SWITCH

코드 스위치
CODE SWITCH

노브
KNOB

로타리 스위치
ROTARY SWITCH

써지 보호 장치
SURGE PROTECTIVE DEVICE

스파크 킬러
SPARK KILLER

LED 인디케이터
LED INDICATOR

노 휴즈 브레카 핸들
N.F.B HANDLE

케이블 그랜드
CABLE GLAND

팬 커버
FAN COVER

힌지/록커/키
HINGE/LOCKER/KEY

로드메타-알피엠메타
LOAD METER-RPM METER

기타 품목
THE OTHER PRODUCTS

써지 보호 장치

SPD

단상형 SINGLE PHASE TYPE

3kA 10kA

K20E	390	K20E	271
	560		471
	680		681
			820
			821
			102
			152
			182

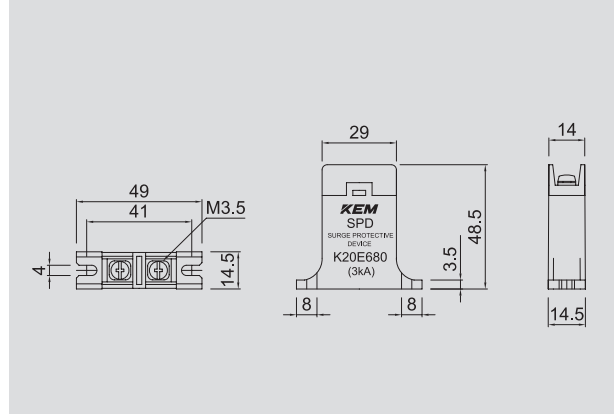

15kA

K25E	271	K25E	102
	471		152
	681		182
	821		

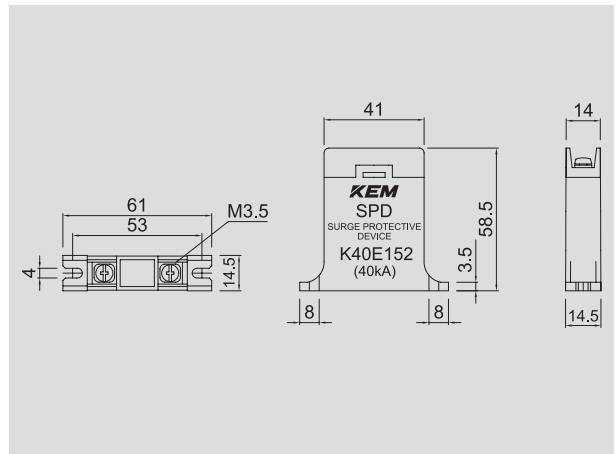

20kA

K32E	201	K32E	821
	271		102
	471		152
	681		182

40kA

K40E	201	K40E	821
	271		102
	471		152
	681		182

50kA

60kA

70kA

K53E	201	K53E	821
	271		102
	471		152
	681		182

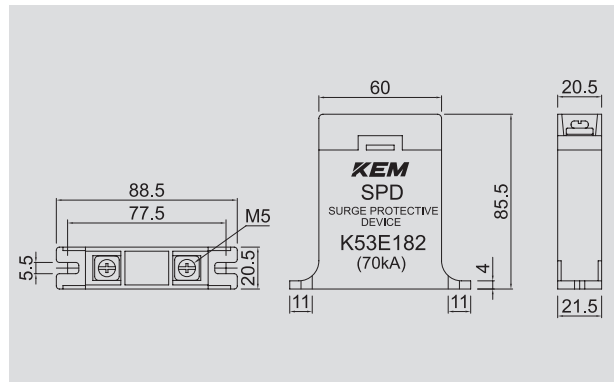

써지 보호 장치

SPD

단상 채널형 SINGLE PHASE CHANNEL TYPE

6kA
KCL15E 471

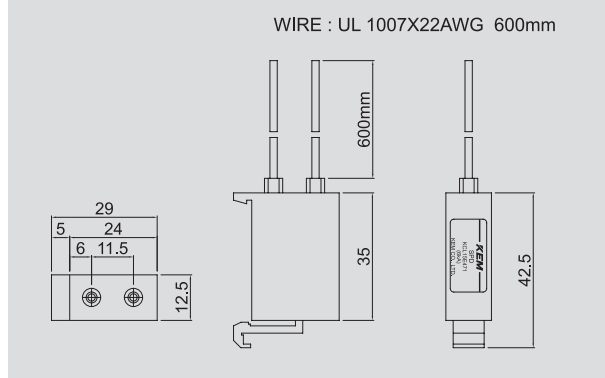

10kA
KCL20E { 471, 821, 102

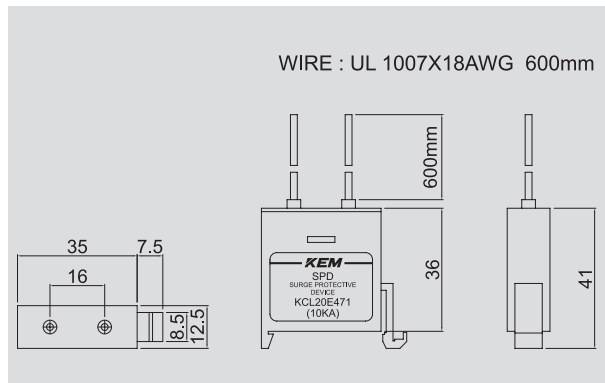

15kA
KCL25E { 471, 821, 102

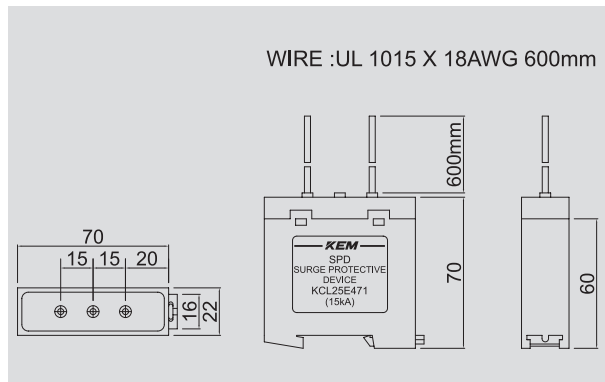

20kA
KCL32E { 471, 821, 102

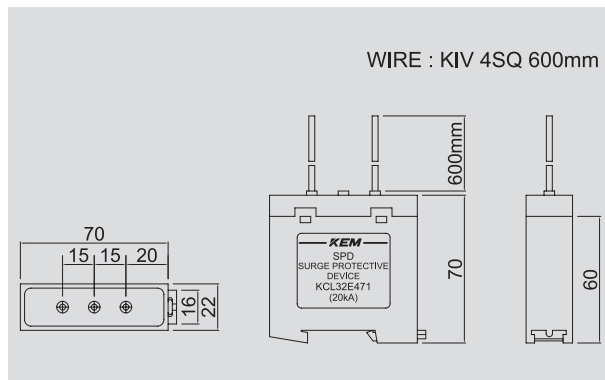

40kA
KCL40E { 471, 821, 102

오일 킬러
OIL KILLER

인터페이스 커버
INTERFACE COVER

정류기
POWER CONVERTOR

역결상 계전기
PHASE MONITORING RELAY

풋 스위치
FOOT SWITCH

푸쉬 버튼 스위치
PUSH BUTTON SWITCH

코드 스위치
CODE SWITCH

노브
KNOB

로타리 스위치
ROTARY SWITCH

**써지 보호 장치
SURGE PROTECTIVE DEVICE**

스파크 킬러
SPARK KILLER

LED 인디케이터
LED INDICATOR

노 휴즈 브레카 핸들
N.F.B HANDLE

케이블 그랜드
CABLE GLAND

팬 커버
FAN COVER

힌지/록커/키
HINGE/LOCKER/KEY

로드메타·알피엠메타
LOAD METER·RPM METER

기타 품목
THE OTHER PRODUCTS

써지 보호 장치

SPD

단상 전원 접지형 SINGLE PHASE+E

※ DC 전용의 단상 전원 접지형은 별도 주문 제작입니다.

10kA

- KC10
 - 120V
 - 220V
 - 380V
 - 440V
 2Y

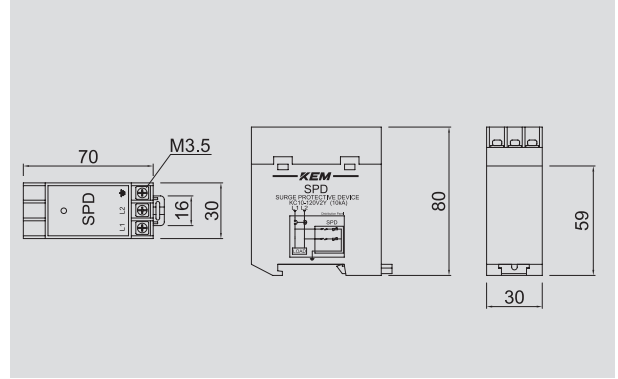

15kA

- KC15
 - 120V
 - 220V
 - 380V
 - 440V
 2Y

20kA

- K20
 - 120V
 - 220V
 - 380V
 - 440V
 2Y

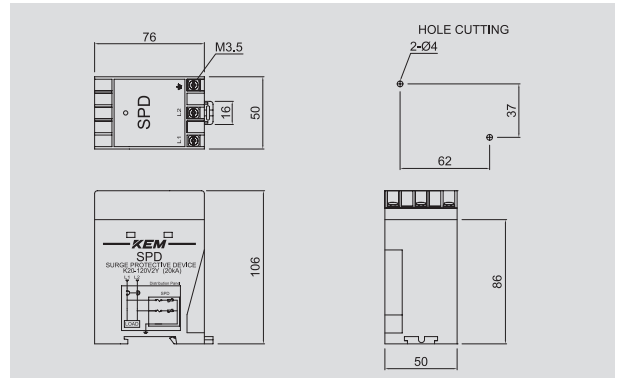

40kA

- K40
 - 120V
 - 220V
 - 380V
 - 440V
 2Y

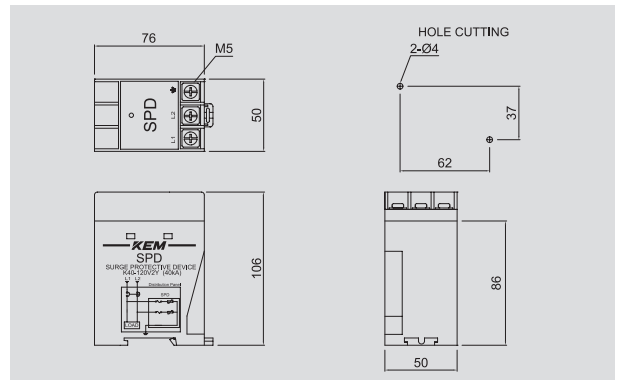

50kA

60kA

70kA

- K70
 - 120V
 - 220V
 - 380V
 - 440V
 2Y



80kA

- K80
 - 120V
 - 220V
 - 380V
 - 440V
 2Y

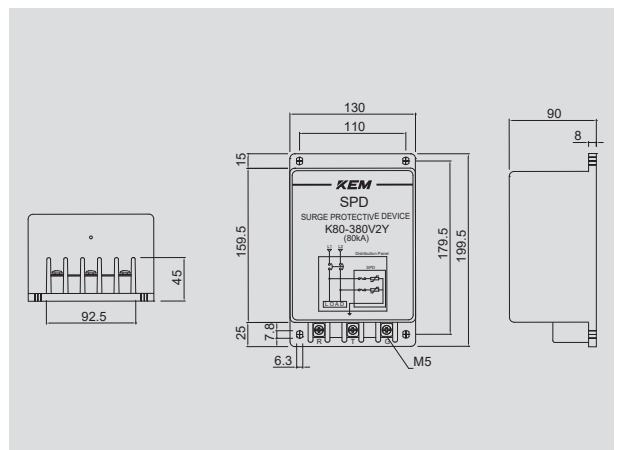

서지 보호 장치

SPD

단상 전원 접지형 SINGLE PHASE+E

* DC 전용의 단상 전원 접지형은 별도 주문 제작입니다.

10kA

- KL10 [120V] 2Y
- [220V]
- [380V]
- [440V]

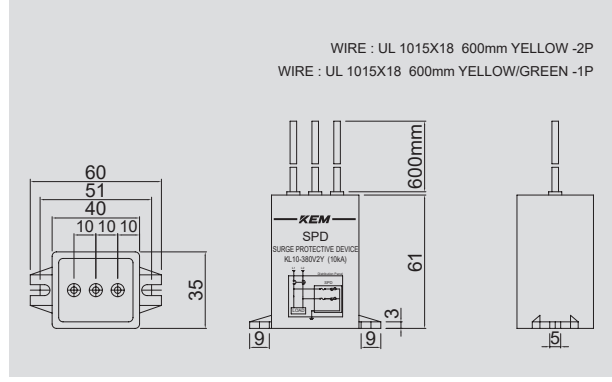

15kA

- KL15 [120V] 2Y
- [220V]
- [380V]
- [440V]

20kA 40kA

- KBL20 [220V] 2Y
- [380V]
- [440V]

- KBL40 [220V] 2Y
- [380V]
- [440V]

70kA

- KBL70 [220V] 2Y
- [380V]
- [440V]

80kA

- KB L80 [220V] 2Y
- [380V]
- [440V]

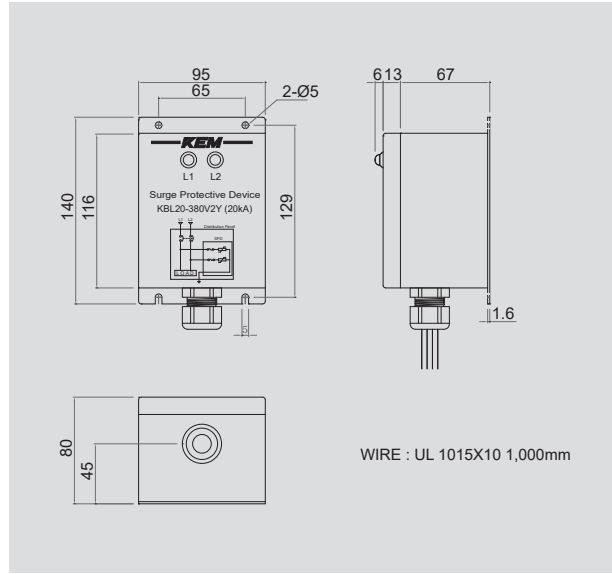

- KES10 [120V] 2Y
- [220V]
- [380V]
- [440V]

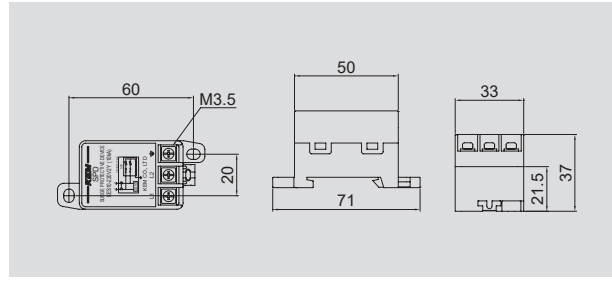

- KEB10 [120V] 2Y
- [220V]
- [380V]
- [440V]

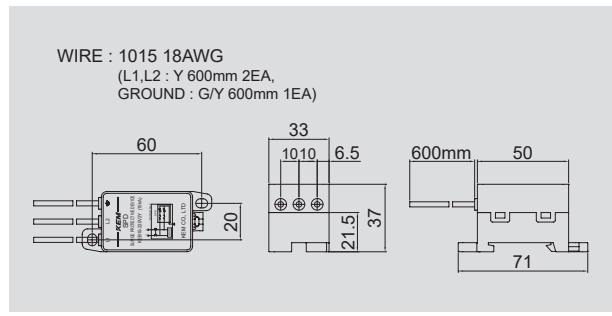

오일 킬러
OIL KILLER

인터페이스 커버
INTERFACE COVER

정류기
POWER CONVERTOR

역결상 계전기
PHASE MONITORING RELAY

풋 스위치
FOOT SWITCH

푸쉬 버튼 스위치
PUSH BUTTON SWITCH

코드 스위치
CODE SWITCH

노브
KNOB

로타리 스위치
ROTARY SWITCH

서지 보호 장치 SURGE PROTECTIVE DEVICE

스파크 킬러
SPARK KILLER

LED 인디케이터
LED INDICATOR

노 휴즈 브레카 핸들
N.F.B HANDLE

케이블 그랜드
CABLE GLAND

팬 커버
FAN COVER

힌지/록커/키
HINGE/LOCKER/KEY

로드메타·알피엠메타
LOAD METER·RPM METER

기타 품목
THE OTHER PRODUCTS

써지 보호 장치

SPD

삼상 전원 접지형 THREE PHASE+E

10kA

KC10 { 220V
380V } 3Y
440V

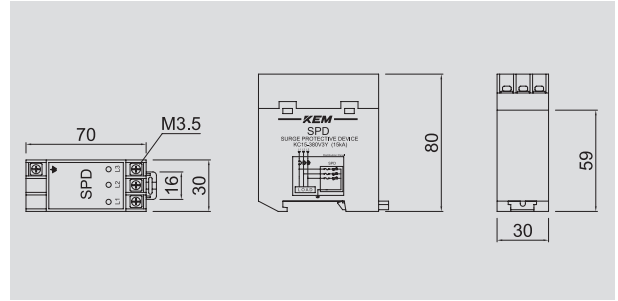

15kA

KC15 { 220V
380V } 3Y
440V



20kA

K20 { 220V
380V } 3Y
440V

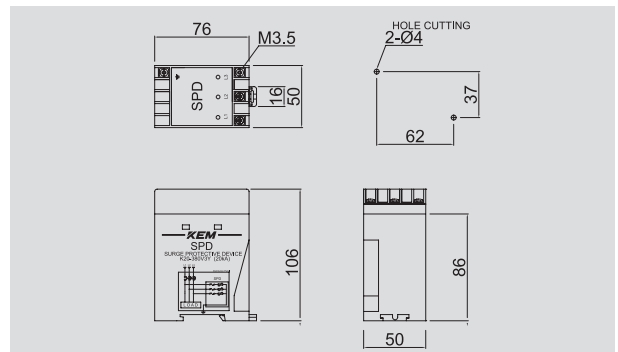

40kA

K40 { 220V
380V } 3Y
440V

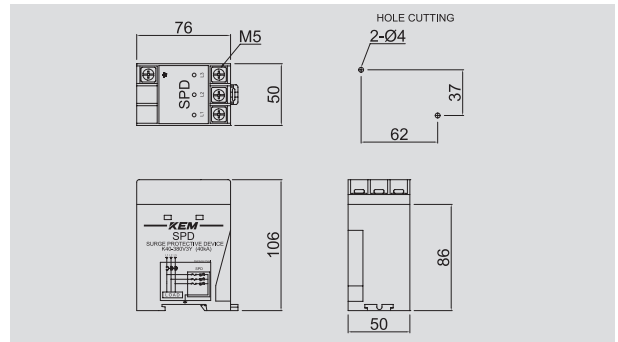

50kA | 60kA | 70kA

K70 { 220V
380V } 3Y
440V

80kA

K80 { 220V
380V } 3Y
440V

120kA

K120 { 220V
380V } 3Y
440V

160kA

K160 { 220V
380V } 3Y
440V

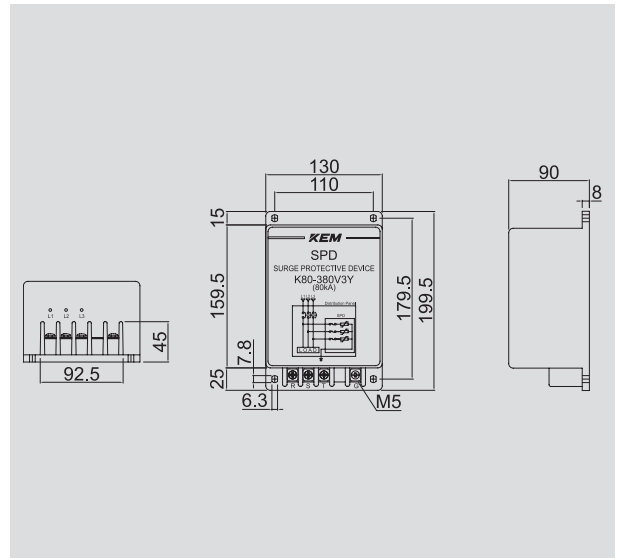

써지 보호 장치

SPD

삼상 전원 접지형 THREE PHASE+ E

40kA
KBL40 { 220V } 3Y
 { 380V }
 { 440V }

70kA
KBL70 { 220V } 3Y
 { 380V }
 { 440V }

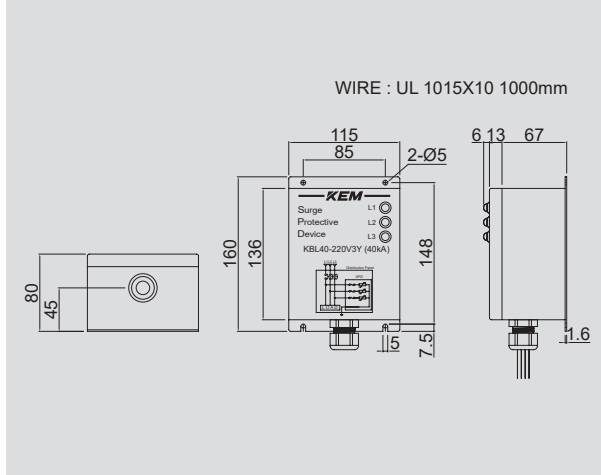

80kA
KBL80 { 220V } 3Y
 { 380V }
 { 440V }

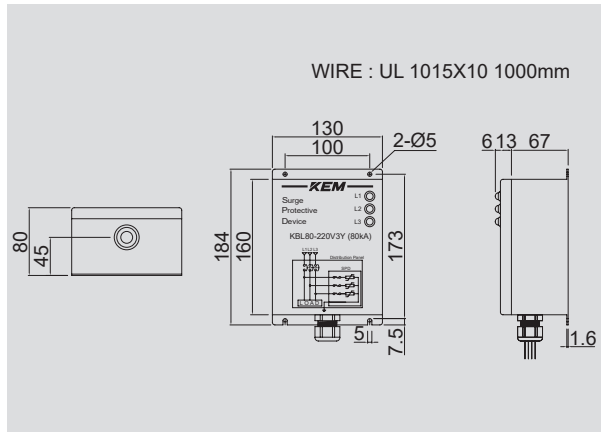

120kA
KBL120 { 220V } 3Y
 { 380V }
 { 440V }

160kA
KBL160 { 220V } 3Y
 { 380V }
 { 440V }

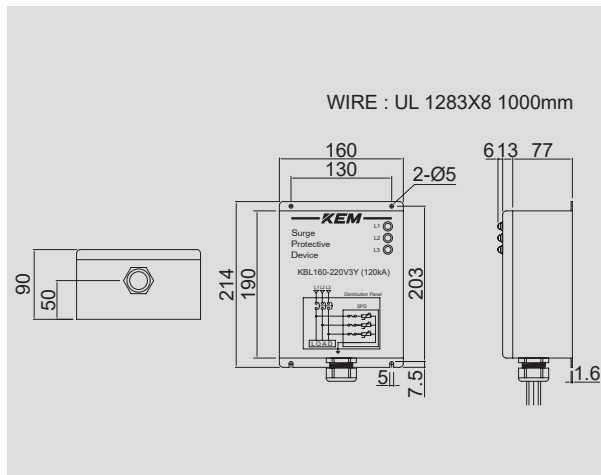

오일 킬러
OIL KILLER

인터페이스 커버
INTERFACE COVER

정류기
POWER CONVERTOR

역결상 계전기
PHASE MONITORING RELAY

풋 스위치
FOOT SWITCH

푸쉬 버튼 스위치
PUSH BUTTON SWITCH

코드 스위치
CODE SWITCH

노브
KNOB

로타리 스위치
ROTARY SWITCH

**써지 보호 장치
SURGE PROTECTIVE DEVICE**

스파크 킬러
SPARK KILLER

LED 인디케이터
LED INDICATOR

노 휴즈 브레카 핸들
N.F.B HANDLE

케이블 그랜드
CABLE GLAND

팬 커버
FAN COVER

힌지/록커/키
HINGE/LOCKER/KEY

로드메터·알피엠메터
LOAD METER-RPM METER

기타 품목
THE OTHER PRODUCTS

써지 보호 장치

SPD

삼상 전원 N 접지형 THREE PHASE+N+E

10kA
K10-380V4Y

15kA
K15-380V4Y

20kA
K20-380V4Y

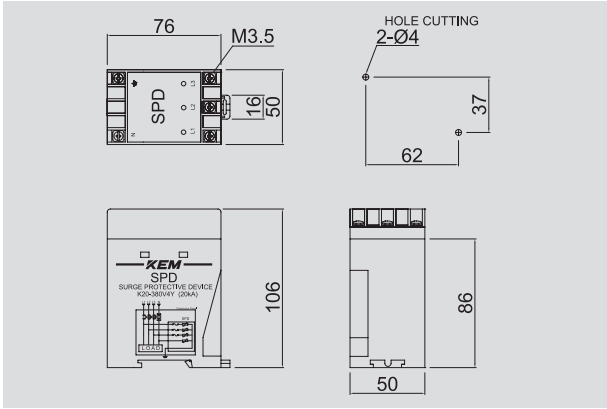

40kA
K40-380V4Y

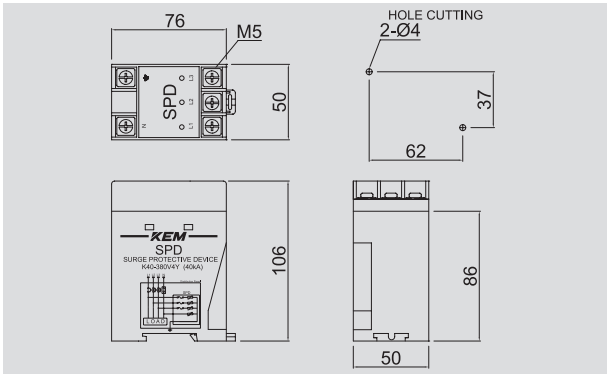

50kA

60kA

70kA

K70-380V4Y

80kA

K80-380V4Y

120kA

K120-380V4Y

160kA

K160-380V4Y

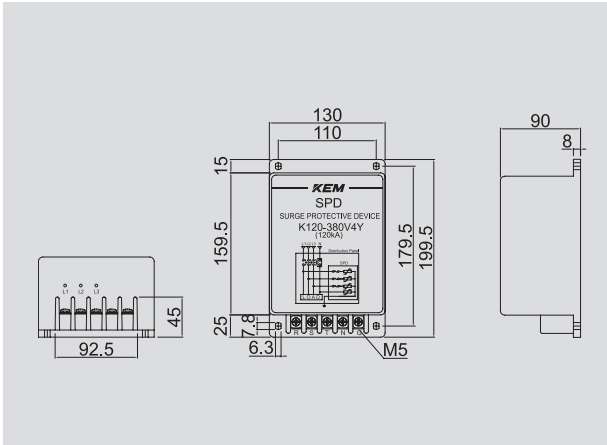

40kA
KBL40-380V4Y

50kA

60kA

70kA

KBL70-380V4Y

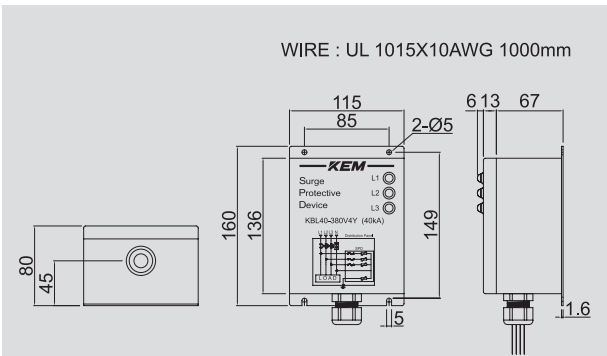

써지 보호 장치

SPD

삼상 전원 N 접지형 THREE PHASE+NE

80kA
KBL80-380V4Y

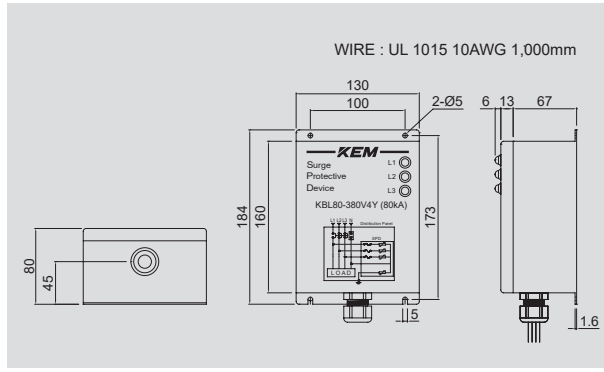

120kA
KBL120-380V4Y

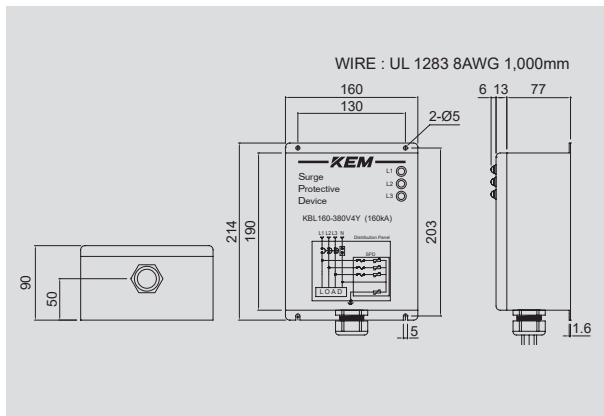

160kA
KBL160-380V4Y

채널 타입 / Channel type

20kA
KSP20-380V4Y

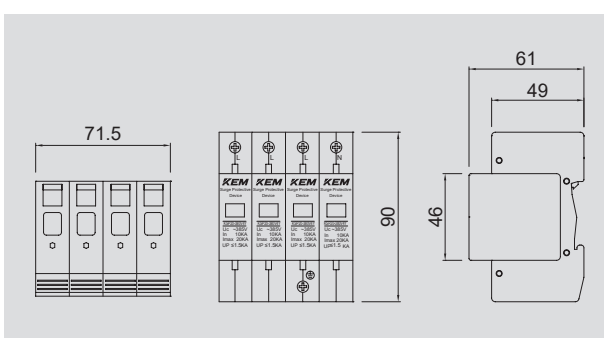

40kA
KSP40-380V4Y

100kA
KSP100-380V4Y

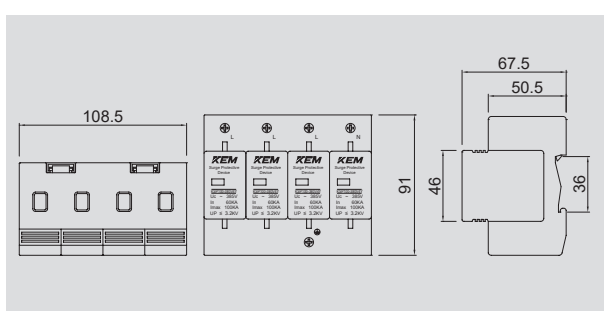

- 오일 킬러
OIL KILLER
- 인터페이스 커버
INTERFACE COVER
- 정류기
POWER CONVERTOR
- 역결상 계전기
PHASE MONITORING RELAY
- 풋 스위치
FOOT SWITCH
- 푸쉬 버튼 스위치
PUSH BUTTON SWITCH
- 코드 스위치
CODE SWITCH
- 노브
KNOB
- 로타리 스위치
ROTARY SWITCH
- 써지 보호 장치
SURGE PROTECTIVE DEVICE**
- 스파크 킬러
SPARK KILLER
- LED 인디케이터
LED INDICATOR
- 노 휴즈 브레카 핸들
N.F.B HANDLE
- 케이블 그랜드
CABLE GLAND
- 팬 커버
FAN COVER
- 힌지/록커/키
HINGE/LOCKER/KEY
- 로드메터·알피엠메터
LOAD METER·RPM METER
- 기타 품목
THE OTHER PRODUCTS

써지 보호 장치

SPD

삼상 전원 N 접지형 THREE PHASE + N + E

안전 커버 타입 / Safety cover type

40kA

KB3-40 [220V
380V
480V] 4YF

80kA

KB3-80 [220V
380V
480V] 4YF

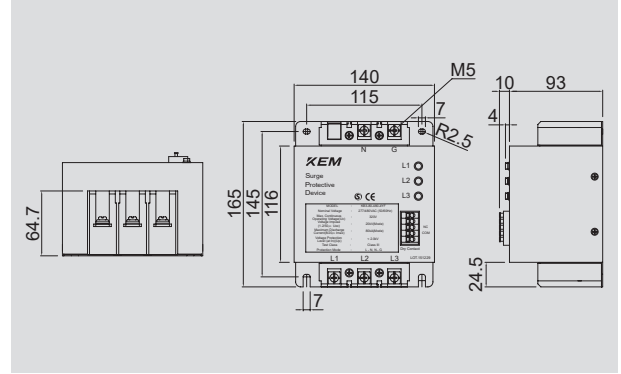

어레스터형 ARRESTER TYPE

정격 전압 / Rated voltage

Arrester type	Nominal voltage at 1mA(DC) current	Max allowable voltage		Max energy (10/1000μs)	Max peak current (8/20μs)	Arrester voltage	Phase
	(V)	AC(V)	DC(V)	(Joule)	1Time(kA)		
K14D471-A3	470 (423~517)	300	385	247	6	350V	Single phase+E
K14D821-A6	820 (738~902)	510	670	344	6	600V	Three phase+E

K14D471-A3

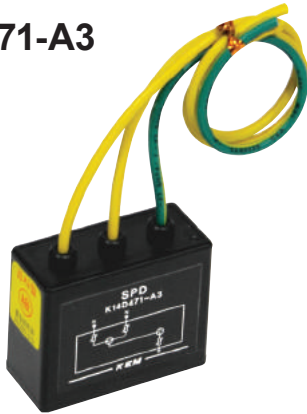

Single phase + Earth type

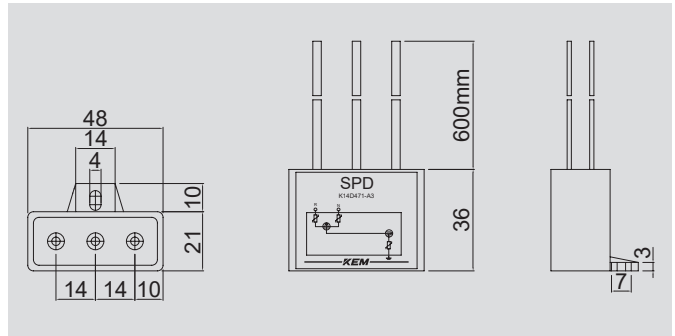

K14D821-A6

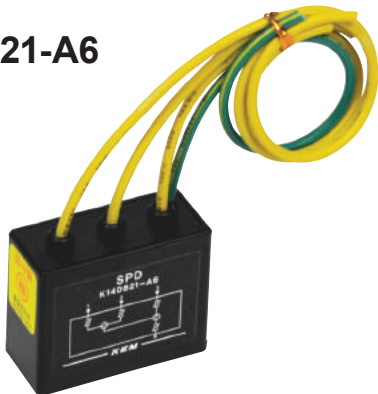

Three phase + Earth type

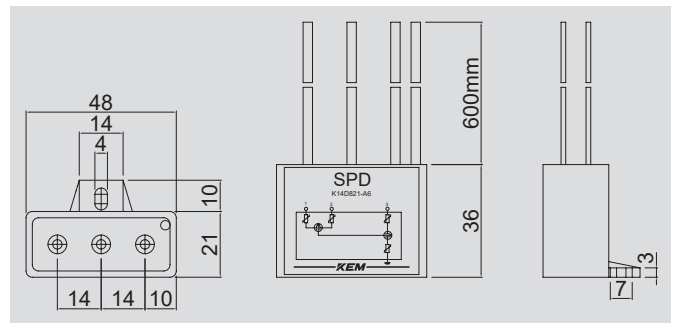

서지 보호 장치

SPD NEW

20kA



- KBL20**
- 220V [2YN, 3YN, 4YN]
 - 380V [2YN, 3YN, 4YN]
 - 480V [2YN, 3YN, 4YN]

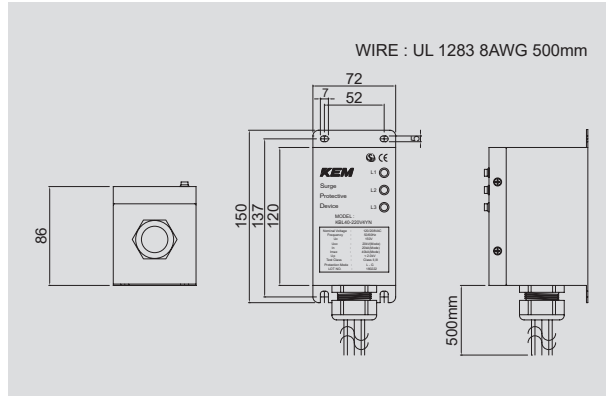

40kA



- KBL40**
- 220V [2YN, 3YN, 4YN]
 - 380V [2YN, 3YN, 4YN]
 - 480V [2YN, 3YN, 4YN]

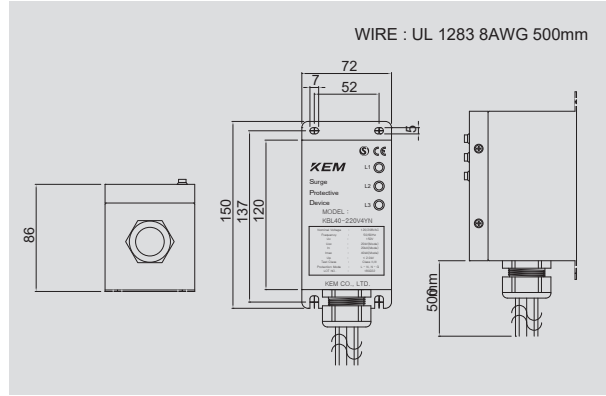

80kA



- KBL80**
- 220V [2YN, 3YN, 4YN]
 - 380V [2YN, 3YN, 4YN]
 - 480V [2YN, 3YN, 4YN]

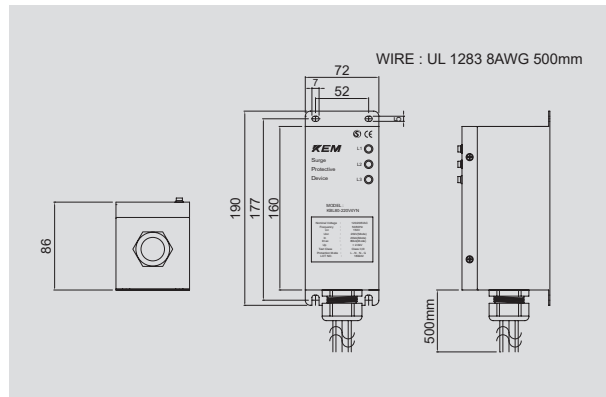

회로도 / Curcuit 삼상전원N접지형 / Three phase+N+E

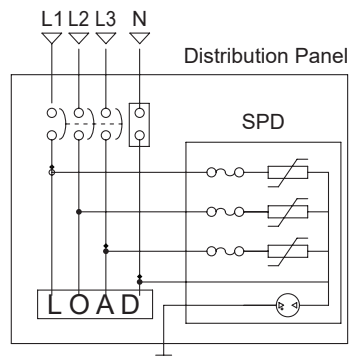

오일 킬러
OIL KILLER

인터페이스 커버
INTERFACE COVER

정류기
POWER CONVERTOR

역결상 계전기
PHASE MONITORING RELAY

풋 스위치
FOOT SWITCH

푸쉬 버튼 스위치
PUSH BUTTON SWITCH

코드 스위치
CODE SWITCH

노브
KNOB

로타리 스위치
ROTARY SWITCH

서지 보호 장치
SURGE PROTECTIVE DEVICE

스파크 킬러
SPARK KILLER

LED 인디케이터
LED INDICATOR

노 휴즈 브레카 핸들
N.F.B HANDLE

케이블 그랜드
CABLE GLAND

팬 커버
FAN COVER

힌지/록커/키
HINGE/LOCKER/KEY

로드메타·알피엠메타
LOAD METER·RPM METER

기타 품목
THE OTHER PRODUCTS

써지 보호 장치

SPD

사 양 / Specification

단상 전원 접지형 / Single phase + E type

* CLASS 2

Parts No.	¹ I _n (8/20μs)	² I _{max} (8/20μs)	Nominal voltage	³ U _c	⁴ U _p	Back-up fuse & CB	Case Size	Protection mode
KB2-40-220-2YF	20kA(Mode)	40kA(Mode)	220~240VAC(50/60Hz)	300V	< 1.5kV	30~50A	A	L - G
KB2-40-380-2YF			380VAC(50/60Hz)	350V	< 2.0kV	30A		
KB2-40-480-2YF			440 ~ 480VAC(50/60Hz)	550V	< 2.5kV	30A		
KB2-80-220-2YF	40kA(Mode)	80kA(Mode)	220~240VAC(50/60Hz)	300V	< 1.5kV	30~50A		
KB2-80-380-2YF			380VAC(50/60Hz)	350V	< 2.0kV	30A		
KB2-80-480-2YF			440 ~ 480VAC(50/60Hz)	550V	< 2.5kV	30A		
KB2-120-220-2YF	60kA(Mode)	120kA(Mode)	220~240VAC(50/60Hz)	300V	< 1.5kV	60~150A		
KB2-120-380-2YF			380VAC(50/60Hz)	350V	< 2.0kV	50~100A		
KB2-120-480-2YF			440 ~ 480VAC(50/60Hz)	550V	< 2.5kV	50~100A		
KB2-160-220-2YF	80kA(Mode)	160kA(Mode)	220~240VAC(50/60Hz)	300V	< 1.5kV	60~150A	B	
KB2-160-380-2YF			380VAC(50/60Hz)	350V	< 2.0kV	50~100A		
KB2-160-480-2YF			440 ~ 480VAC(50/60Hz)	550V	< 2.5kV	50~100A		
KB2-200-220-2YF	100kA(Mode)	200kA(Mode)	220~240VAC(50/60Hz)	300V	< 1.5kV	60~150A		
KB2-200-380-2YF			380VAC(50/60Hz)	350V	< 2.0kV	50~100A		
KB2-200-480-2YF			440 ~ 480VAC(50/60Hz)	550V	< 2.5kV	50~100A		

¹I_n : 방전전류(8/20μs) ²I_{max} : 최대방전전류(8/20μs) ³U_c : 최대연속전압 ⁴U_p : 전압보호레벨
¹I_n : Nominal discharge current(8/20μs) ²I_{max} : Maximum discharge current(8/20μs)
³U_c : Maximum continuous operating voltage ⁴U_p : Voltage protection level

써지 보호 장치

SPD

삼상 전원 접지형 / Three phase + E type

* CLASS 2

Parts No.	¹ I _n (8/20μs)	³ I _{max} (8/20μs)	Nominal voltage	⁴ U _c	⁵ U _p	Back-up fuse & CB	Case size	Protection mode
KB2-40-220-3YF	20kA(Mode)	40kA(Mode)	220~240VAC(50/60Hz)	300V	< 1.5kV	30~50A	A	L - G
KB2-40-380-3YF			380VAC(50/60Hz)	350V	< 2.0kV	30A		
KB2-40-480-3YF			440~480VAC(50/60Hz)	550V	< 2.5kV	30A		
KB2-80-220-3YF	40kA(Mode)	80kA(Mode)	220~240VAC(50/60Hz)	300V	< 1.5kV	30~50A		
KB2-80-380-3YF			380VAC(50/60Hz)	350V	< 2.0kV	30A		
KB2-80-480-3YF			440~480VAC(50/60Hz)	550V	< 2.5kV	30A		
KB2-120-220-3YF	60kA(Mode)	120kA(Mode)	220~240VAC(50/60Hz)	300V	< 1.5kV	60~150A	B	L - G
KB2-120-380-3YF			380VAC(50/60Hz)	350V	< 2.0kV	50~100A		
KB2-120-480-3YF			440~480VAC(50/60Hz)	550V	< 2.5kV	50~100A		
KB2-160-220-3YF	80kA(Mode)	160kA(Mode)	220~240VAC(50/60Hz)	300V	< 1.5kV	60~150A	B	L - G
KB2-160-380-3YF			380VAC(50/60Hz)	350V	< 2.0kV	50~100A		
KB2-160-480-3YF			440~480VAC(50/60Hz)	550V	< 2.5kV	50~100A		
KB2-200-220-3YF	100kA(Mode)	200kA(Mode)	220~240VAC(50/60Hz)	300V	< 1.5kV	60~150A	B	L - G
KB2-200-380-3YF			380VAC(50/60Hz)	350V	< 2.0kV	50~100A		
KB2-200-480-3YF			440~480VAC(50/60Hz)	550V	< 2.5kV	50~100A		

* CLASS 3

Parts No.	² U _{oc} (1.2/50μs)	³ I _{max} (8/20μs)	Nominal voltage	⁴ U _c	⁵ U _p	Back-up fuse & CB	Case size	Protection mode
KB3-40-220-3YF	20kV(Mode)	40kA(Mode)	220~240VAC(50/60Hz)	300V	< 1.5kV	30~50A	A	L - G
KB3-40-380-3YF			380VAC(50/60Hz)	350V	< 2.0kV	30A		
KB3-40-480-3YF			440~480VAC(50/60Hz)	550V	< 2.5kV	30A		
KB3-80-220-3YF		80kA(Mode)	220~240VAC(50/60Hz)	300V	< 1.5kV	30~50A		
KB3-80-380-3YF			380VAC(50/60Hz)	350V	< 2.0kV	30A		
KB3-80-480-3YF			440~480VAC(50/60Hz)	550V	< 2.5kV	30A		
KB3-120-220-3YF		120kA(Mode)	220~240VAC(50/60Hz)	300V	< 1.5kV	60~150A	B	L - G
KB3-120-380-3YF			380VAC(50/60Hz)	350V	< 2.0kV	50~100A		
KB3-120-480-3YF			440~480VAC(50/60Hz)	550V	< 2.5kV	50~100A		
KB3-160-220-3YF		160kA(Mode)	220~240VAC(50/60Hz)	300V	< 1.5kV	60~150A	B	L - G
KB3-160-380-3YF			380VAC(50/60Hz)	350V	< 2.0kV	50~100A		
KB3-160-480-3YF			440~480VAC(50/60Hz)	550V	< 2.5kV	50~100A		
KB3-200-220-3YF	200kA(Mode)	220~240VAC(50/60Hz)	300V	< 1.5kV	60~150A	B	L - G	
KB3-200-380-3YF		380VAC(50/60Hz)	350V	< 2.0kV	50~100A			
KB3-200-480-3YF		440~480VAC(50/60Hz)	550V	< 2.5kV	50~100A			

¹I_n : 방전전류(8/20μs) ²U_{oc} : 방전전압(1.2/50μs) ³I_{max} : 최대방전전류(8/20μs) ⁴U_c : 최대연속전압 ⁵U_p : 전압보호레벨

¹I_n : Nominal discharge current(8/20μs) ²U_{oc} : Discharge voltage(1.2/50μs)

³I_{max} : Maximum discharge current(8/20μs) ⁴U_c : Maximum continuous operating voltage ⁵U_p : Voltage protection level

- 오일 킬러
OIL KILLER
- 인터페이스 커버
INTERFACE COVER
- 정류기
POWER CONVERTOR
- 역결상 계전기
PHASE MONITORING RELAY
- 풋 스위치
FOOT SWITCH
- 푸쉬 버튼 스위치
PUSH BUTTON SWITCH
- 코드 스위치
CODE SWITCH
- 노브
KNOB
- 로타리 스위치
ROTARY SWITCH
- 써지 보호 장치
SURGE PROTECTIVE DEVICE**
- 스파크 킬러
SPARK KILLER
- LED 인디케이터
LED INDICATOR
- 노 휴즈 브레카 핸들
N.F.B HANDLE
- 케이블 그랜드
CABLE GLAND
- 팬 커버
FAN COVER
- 힌지/록커/키
HINGE/LOCKER/KEY
- 로드메타·알피엠메타
LOAD METER·RPM METER
- 기타 품목
THE OTHER PRODUCTS

써지 보호 장치

SPD

삼상 전원 N 접지형 / Three phase + N + E type

*** CLASS 2**

Parts No.	¹ I _n (8/20μs)	³ I _{max} (8/20μs)	Nominal voltage	⁴ U _c	⁵ U _p	Back-up fuse & CB	Case size	Protection mode
KB2-40-220-4YF	20kA (Mode)	40kA (Mode)	120/208VAC(50/60Hz)	150V	< 1.5kV	30~50A	A	L - N, N - G
KB2-40-380-4YF			220/380VAC(50/60Hz)	320V	< 2.0kV	30A		
KB2-40-480-4YF			240/415VAC~277/480VAC(50/60Hz)	350V	< 2.0kV	30A		
KB2-80-220-4YF	40kA (Mode)	80kA (Mode)	120/208VAC(50/60Hz)	150V	< 1.5kV	30~50A		
KB2-80-380-4YF			220/380VAC(50/60Hz)	320V	< 2.0kV	30A		
KB2-80-480-4YF			240/415VAC~277/480VAC(50/60Hz)	350V	< 2.0kV	30A		
KB2-120-220-4YF	60kA (Mode)	120kA (Mode)	120/208VAC(50/60Hz)	150V	< 1.5kV	60~150A		
KB2-120-380-4YF			220/380VAC(50/60Hz)	320V	< 2.0kV	50~100A		
KB2-120-480-4YF			240/415VAC~277/480VAC(50/60Hz)	350V	< 2.0kV	50~100A		
KB2-160-220-4YF	80kA (Mode)	160kA (Mode)	120/208VAC(50/60Hz)	150V	< 1.5kV	60~150A	B	
KB2-160-380-4YF			220/380VAC(50/60Hz)	320V	< 2.0kV	50~100A		
KB2-160-480-4YF			240/415VAC~277/480VAC(50/60Hz)	350V	< 2.0kV	50~100A		
KB2-200-220-4YF	100kA (Mode)	200kA (Mode)	120/208VAC(50/60Hz)	150V	< 1.5kV	60~150A		
KB2-200-380-4YF			220/380VAC(50/60Hz)	320V	< 2.0kV	50~100A		
KB2-200-480-4YF			240/415VAC~277/480VAC(50/60Hz)	350V	< 2.0kV	50~100A		

*** CLASS 3**

Parts No.	² U _{oc} (1.2/50μs)	³ I _{max} (8/20μs)	Nominal voltage	⁴ U _c	⁵ U _p	Back-up fuse & CB	Case size	Protection mode
KB3-40-220-4YF	20kV (Mode)	40kA (Mode)	120/208VAC(50/60Hz)	150V	< 1.5kV	30~50A	A	L - N, N - G
KB3-40-380-4YF			220/380VAC(50/60Hz)	320V	< 2.0kV	30A		
KB3-40-480-4YF			240/415VAC~277/480VAC(50/60Hz)	350V	< 2.0kV	30A		
KB3-80-220-4YF		80kA (Mode)	120/208VAC(50/60Hz)	150V	< 1.5kV	30~50A		
KB3-80-380-4YF			220/380VAC(50/60Hz)	320V	< 2.0kV	30A		
KB3-80-480-4YF			240/415VAC~277/480VAC(50/60Hz)	320V	< 2.0kV	30A		
KB3-120-220-4YF		120kA (Mode)	120/208VAC(50/60Hz)	150V	< 1.5kV	60~150A		
KB3-120-380-4YF			220/380VAC(50/60Hz)	320V	< 2.0kV	50~100A		
KB3-120-480-4YF			240/415VAC~277/480VAC(50/60Hz)	350V	< 2.0kV	50~100A		
KB3-160-220-4YF		160kA (Mode)	120/208VAC(50/60Hz)	150V	< 1.5kV	60~150A	B	
KB3-160-380-4YF			220/380VAC(50/60Hz)	320V	< 2.0kV	50~100A		
KB3-160-480-4YF			240/415VAC~277/480VAC(50/60Hz)	350V	< 2.0kV	50~100A		
KB3-200-220-4YF		200kA (Mode)	120/208VAC(50/60Hz)	150V	< 1.5kV	60~150A		
KB3-200-380-4YF			220/380VAC(50/60Hz)	320V	< 2.0kV	50~100A		
KB3-200-480-4YF			240/415VAC~277/480VAC(50/60Hz)	350V	< 2.0kV	50~100A		

¹I_n : 방전전류(8/20μs) ²U_{oc} : 방전전압(1.2/50μs) ³I_{max} : 최대방전전류(8/20μs) ⁴U_c : 최대연속전압 ⁵U_p : 전압보호레벨
¹I_n : Nominal discharge current(8/20μs) ²U_{oc} : Discharge voltage(1.2/50μs)
³I_{max} : Maximum discharge current(8/20μs) ⁴U_c : Maximum continuous operating voltage ⁵U_p : Voltage protection level

KB type 공동 사양 / KB type specification

	Cable		외함 사이즈 / Case size (Width X Height X Depth)	케이블 길이 / Cable length	외함 및 취부방법 / Mounting method	표시장치 / Indicator
	Power	PE				
CLASS 2	6/10sq	6/10sq	A type - 140mm X 165mm X 93mm B type - 150mm X 225mm X 93mm	500mm 이내 (Less than 500mm)	Steel case / M4 나사 체결방식 (M4 Screw wall mounting)	정상 : 녹색 LED 점등 (Normal : Green lights on)
CLASS 3	6sq	6sq				

기압 / Atmosphere	고도 / Altitude	사용온도 및 습도 / Operating temperature	알람 기능 / Alarm function
80 ~ 106kPa	+2,000 ~ -500m	-40~80°C, 5~95% (결로 없음) (Non-condensing)	Dry Contact(NC,COM)

써지 보호 장치

SPD

단상 전원 접지형 / Single phase + E type

Parts No.	¹ I _n (8/20μs)	² I _{max} (8/20μs)	Nominal voltage	³ U _c	⁴ U _p	Back-up fuse & CB	Case Size	Protection mode
KBL20-220-2YN	10kA(Mode)	20kA(Mode)	220VAC(50/60Hz)	300V	< 2.0kV	30A	A	L - G
KBL20-380-2YN			380VAC(50/60Hz)	350V				
KBL20-480-2YN			480VAC(50/60Hz)	550V				
KBL40-220-2YN	20kA(Mode)	40kA(Mode)	220VAC(50/60Hz)	300V	< 2.0kV	30A	A	
KBL40-380-2YN			380VAC(50/60Hz)	350V				
KBL40-480-2YN			480VAC(50/60Hz)	550V				
KBL80-220-2YN	40kA(Mode)	20kA(Mode)	220VAC(50/60Hz)	300V	< 2.0kV	50A	B	
KBL80-380-2YN			380VAC(50/60Hz)	350V				
KBL80-480-2YN			480VAC(50/60Hz)	550V				

삼상 전원 접지형 / Three phase + E type

Parts No.	¹ I _n (8/20μs)	² I _{max} (8/20μs)	Nominal voltage	³ U _c	⁴ U _p	Back-up fuse & CB	Case Size	Protection mode
KBL20-220-3YN	10kA(Mode)	20kA(Mode)	220VAC(50/60Hz)	300V	< 2.0kV	30A	A	L - G
KBL20-380-3YN			380VAC(50/60Hz)	350V				
KBL20-480-3YN			480VAC(50/60Hz)	550V				
KBL40-220-3YN	20kA(Mode)	40kA(Mode)	220VAC(50/60Hz)	300V	< 2.0kV	30A	A	
KBL40-380-3YN			380VAC(50/60Hz)	350V				
KBL40-480-3YN			480VAC(50/60Hz)	550V				
KBL80-220-3YN	40kA(Mode)	80kA(Mode)	220VAC(50/60Hz)	300V	< 2.0kV	50A	B	
KBL80-380-3YN			380VAC(50/60Hz)	350V				
KBL80-480-3YN			480VAC(50/60Hz)	550V				

삼상 전원 N 접지형 / Three phase + N + E type

Parts No.	¹ I _n (8/20μs)	² I _{max} (8/20μs)	Nominal voltage	³ U _c	⁴ U _p	Back-up fuse & CB	Case Size	Protection mode
KBL20-220V4YN	10kA(Mode)	20kA(Mode)	120/208VAC(50/60Hz)	150V	< 2.0kV	30A	A	L - N N - G
KBL20-380V4YN			220/380VAC(50/60Hz)	320V				
KBL20-480V4YN			277/480VAC(50/60Hz)	350V				
KBL40-220V4YN	20kA(Mode)	40kA(Mode)	120/208VAC(50/60Hz)	150V				
KBL40-380V4YN			220/380VAC(50/60Hz)	320V				
KBL40-480V4YN			277/480VAC(50/60Hz)	350V				
KBL80-220V4YN	40kA(Mode)	80kA(Mode)	120/208VAC(50/60Hz)	150V				
KBL80-380V4YN			220/380VAC(50/60Hz)	320V				
KBL80-480V4YN			277/480VAC(50/60Hz)	350V				

¹I_n : 방전전류(8/20μs) ²I_{max} : 최대방전전류(8/20μs) ³U_c : 최대연속전압 ⁴U_p : 전압보호레벨

¹I_n : Nominal discharge current(8/20μs) ²I_{max} : Maximum discharge current(8/20μs)

³U_c : Maximum continuous operating voltage ⁴U_p : Voltage protection level

KBL type 공통 사양 / KBL type specification

Cable		외함 사이즈 / Case size (Width X Height X Depth)	케이블 길이 / Cable length	외함 및 취부방법 / Mounting method	표시장치 / Indicator
Power	PE				
UL1283	8AWG	A type - 72mm X 150mm X 86mm B type - 72mm X 190mm X 86mm	500mm 이내 (Less than 500mm)	Steel case / M4 나사 체결방식 (M4 Screw wall mounting)	정상 : 녹색 LED 점등 (Normal : Green lights on)

기압 / Atmosphere	고도 / Altitude	사용온도 및 습도 / Operating temperature
80 ~ 106kPa	+2,000 ~ -500m	-40~80°C, 5~95% (결로 없음) (Non-condensing)

- 오일 킬러
OIL KILLER
- 인터페이스 커버
INTERFACE COVER
- 정류기
POWER CONVERTOR
- 역결상 계전기
PHASE MONITORING RELAY
- 풋 스위치
FOOT SWITCH
- 푸쉬 버튼 스위치
PUSH BUTTON SWITCH
- 코드 스위치
CODE SWITCH
- 노브
KNOB
- 로타리 스위치
ROTARY SWITCH
- 써지 보호 장치
SURGE PROTECTIVE DEVICE**
- 스파크 킬러
SPARK KILLER
- LED 인디케이터
LED INDICATOR
- 노 휴즈 브레카 핸들
N.F.B HANDLE
- 케이블 그랜드
CABLE GLAND
- 팬 커버
FAN COVER
- 힌지/록커/키
HINGE/LOCKER/KEY
- 로드메타·알피엠메타
LOAD METER·RPM METER
- 기타 품목
THE OTHER PRODUCTS

써지 킬러 - MC, 릴레이용

SURGE KILLER - MC, relay type

특징

1. 응답성이 뛰어나며 급격한 고주파성 펄스 전압도 흡수 가능합니다.
2. 제한전압 특성이 우수합니다.
3. 써지 흡수 능력이 큼니다.
4. 전압, 전류 특성이 대칭으로 되어 있을 뿐 아니라 +극 또는 -극성 써지를 같은 성능으로 흡수합니다.
5. 정격 전력이 크고 신뢰성이 높습니다.

용도

1. 각종 반도체 (다이오드, 사이리스터, 트랜지스터, IC 등)의 써지 과전압으로부터 보호
2. 인버터 사용 회로에 써지 트러블 시 안정적으로 보호
3. 각종 계측기, 제어기기, 통신, 방송 기기 등의 유도전파에 의한 써지를 보호
4. 가전제품, 음향기기 등의 유도 전파에 의한 개폐 써지를 보호
5. 반도체 제조 및 관련 장비
6. 조선, 자동차, 철도·지하철 설비, 원자력 장비, 항공·공항 장비, 의료장비, 소방 경보기, 자동화 라인, 방위 산업 등의 전원 분전함 보호.

Characteristics

1. It's responses are wonderful and it can absorb even the abrupt pulse voltage.
2. It's features concerning clamping voltage are great.
3. It's surge absorption capacity is good.
4. Voltage and current features place in symmetrical forms. In addition, it can absorb the + or - polarity surge as the same capacity.
5. Rated electric power is high and it's reliability is great.

Use

1. It's protective roles are played against the overvoltage of diverse semiconductors (diodes, thyristors, transistors, IC).
2. It prevents overvoltage of diverse relays and protect contact points.
3. It protects surge from inductively electric waves of various counters, controllers, and communication and broadcasting equipments.
4. Protect the opening and breaking surge by induction electric wave such as home appliance and sound device.
5. Semiconductor manufacturing equipment.
6. It protects from shipbuilding, vehicle, train-subway facilities, a nuclear powered plant, air port, aviation, medical facilities, firefighting equipment, factory automation's facilities, main distribution box of defense industry, etc.

사용 예 / Use Example

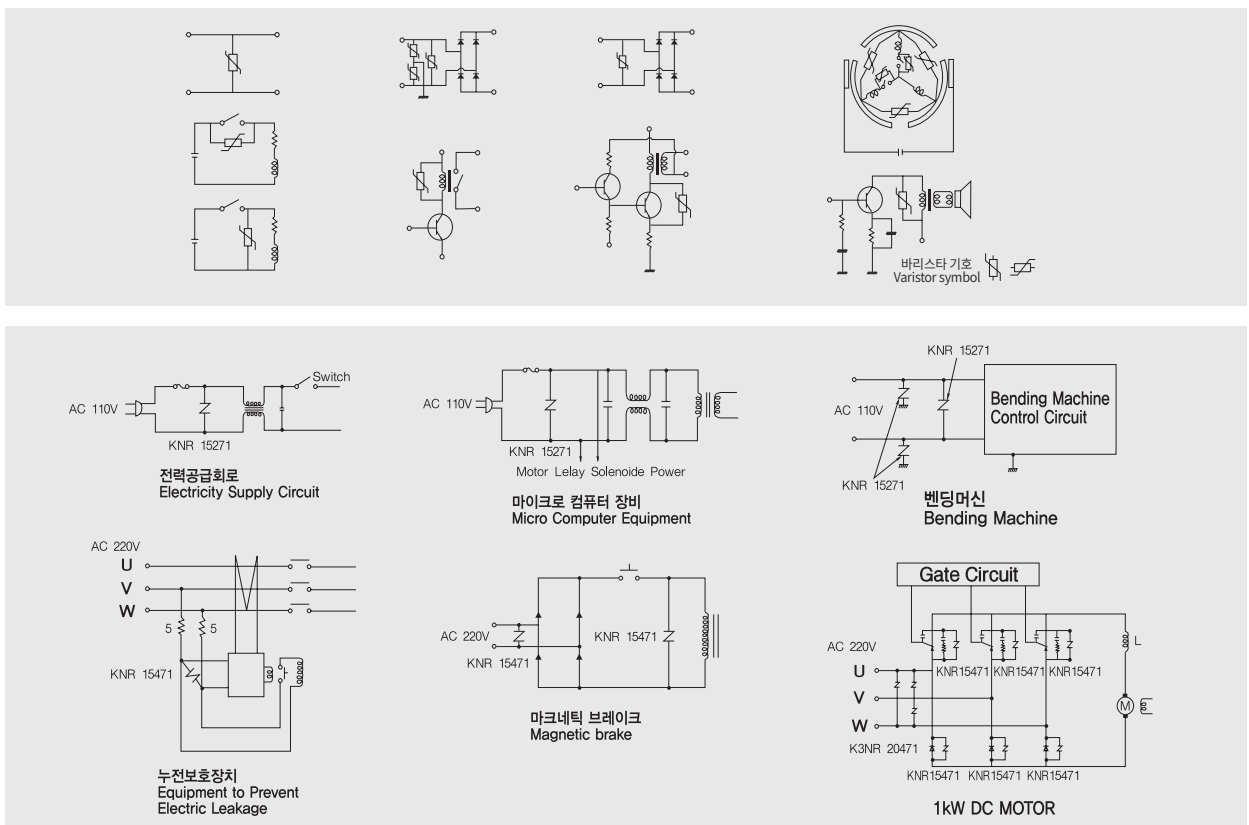



써지 킬러 - MC 릴레이용

SURGE KILLER - MC, relay type

형식

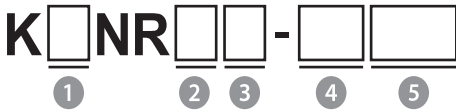

①	위 상	무	단상
		3	삼상
②	전 압	무	저전압
		H	고전압
③	형 식	무	기본 전선형
		B	볼트 취부형
		T	마그네트 코일 단자형
		M	채널 마그네트 일체형
		C	채널형
④	바리스타 크기	10	10Ø
		15	15Ø
		20	20Ø
⑤	바리스타 전압	390	39V
		560	56V
		820	82V
		121	120V
		221	220V
		271	270V
		471	470V
		821	820V
		102	1,000V
		152	1,500V
182	1,800V		

Type

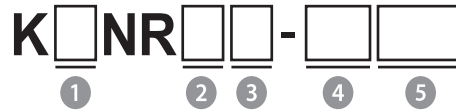

①	Phase	None	Single phase
		3	Three phase
②	Voltage	None	Low voltage
		H	High voltage
③	Type	None	Standard wire type
		B	Detachable bolt type
		T	Magnet coil terminal type
		M	Channel internal magnet type
		C	Channel type
④	Varista size	10	10Ø
		15	15Ø
		20	20Ø
⑤	Varista Voltage	390	39V
		560	56V
		820	82V
		121	120V
		221	220V
		271	270V
		471	470V
		821	820V
		102	1,000V
		152	1,500V
182	1,800V		

사 양 / Specification

단상형 / Single phase type

Model	Nominal voltage at 1mA(DC) current	Max allowable voltage		Max energy (10/1000µs)	Max peak current (8/20µs)
	(V)	AC(V)	DC(V)	(Joule)	1Time(kA)
KNR-15390	39(35~43)	25	31	12	2
KNR-15560	56(50~62)	35	45	18	2
KNR-15121	120(108~132)	75	100	38	6
KNRS-10221	220(198~242)	140	180	35	3.5
KNR-15271	270(243~297)	175	225	85	6
KNR-15471	470(423~517)	300	385	148	6
KNR-20390	39(35~43)	25	31	20	3
KNR-20560	56(50~62)	35	45	29	3
KNR-20121	56(50~62)	35	45	29	3
KNR-20471	470(423~517)	300	385	247	10
KNRD-15271	270(243~297)	175	225	142	10
KNRD-15390	39(35~43)	25	31	12	2
KNRD-15471	470(423~517)	300	385	247	10
KNRD-15560	56(50~62)	35	45	18	2
KNRD-15820	82(74~90)	50	65	26	6
KNR-10271R	270(243~297)	175	225	43	3.5
KNR-10471R	470(423~517)	300	385	74	3.5

Model	Nominal voltage at 1mA(DC) current	Max allowable voltage		Max energy (10/1000µs)	Max peak current (8/20µs)
	(V)	AC(V)	DC(V)	(Joule)	1Time(kA)
KNRT-10271S	270(243~297)	175	225	43	3.5
KNRT-10471S	470(423~517)	300	385	74	3.5
KNRDT-10820S	82(74~90)	50	65	26	3.5
KNRT-15390	39(35~43)	25	31	12	2
KNRT-15560	56(50~62)	35	45	18	2
KNRT-15121	120(108~132)	75	100	38	6
KNRT-15271	270(243~297)	175	225	85	6
KNRT-15471	470(423~517)	300	385	148	6
KNRDT-15390	39(35~43)	25	31	12	2
KNRDT-15560	56(50~62)	35	45	18	2
KNRDT-15820	82(74~90)	50	65	26	6
KNRDT-15271	270(243~297)	175	225	85	6
KNRDT-15471	470(423~517)	300	385	148	6
KNRC-15271	270(243~297)	175	225	85	6
KNRC-15471	470(423~517)	300	385	148	6
KNRC-20471	470(423~517)	300	385	247	10
KNRHC-20821	820(738~902)	510	670	344	10

- 오일 킬러
OIL KILLER
- 인터페이스 커버
INTERFACE COVER
- 정류기
POWER CONVERTOR
- 역결상 계전기
PHASE MONITORING RELAY
- 풋 스위치
FOOT SWITCH
- 푸쉬 버튼 스위치
PUSH BUTTON SWITCH
- 코드 스위치
CODE SWITCH
- 노브
KNOB
- 로타리 스위치
ROTARY SWITCH
- 써지 보호 장치
SURGE PROTECTIVE DEVICE**
- 스파크 킬러
SPARK KILLER
- LED 인디케이터
LED INDICATOR
- 노 휴즈 브레카 핸들
N.F.B HANDLE
- 케이블 그랜드
CABLE GLAND
- 팬 커버
FAN COVER
- 힌지/록커/키
HINGE/LOCKER/KEY
- 로드메터·알피엠메터
LOAD METER·RPM METER
- 기타 품목
THE OTHER PRODUCTS

써지 킬러 - MC, 릴레이용

SURGE KILLER - MC, relay type

삼상형 / Three phase type

Model	Nominal voltage at 1mA(DC) current	Max allowable voltage		Max Energy (10/1000 μ s)	Max peak current (8/20 μ s)
	(V)	AC(V)	DC(V)	(Joule)	1Time(kA)
K3NRD-15471	470 (423~517)	300	385	148	6
K3NR-20471	470 (423~517)	300	385	247	10
K3NRH-20821	820 (738~902)	510	670	344	
K3NRH-20102	1,000 (900~1,100)	625	825	420	
K3NRH-20152	1,500 (1,350~1,650)	900	1,220	629	
K3NRB-20471	470 (423~517)	300	385	247	10
K3NRB-25471	470 (423~517)	300	385	315	15
K3NRHB-25821	820 (738~902)	510	670	420	
K3NRHB-25102	1,000 (900~1,100)	625	825	525	
K3NRHB-25152	1,500 (1,350~1,650)	900	1,220	700	
K3NRC-32471	470 (423~517)	300	385	567	20
K3NRHC-32821	820 (738~902)	510	670	763	
K3NRHC-32102	1,000 (900~1,100)	625	825	868	
K3NRHC-32152	1,500 (1,350~1,650)	900	1,220	1,092	
K3NRC-40471	470 (423~517)	300	385	707	40
K3NRHC-40821	820 (738~902)	510	670	952	
K3NRHC-40102	1,000 (900~1,100)	625	825	1,092	
K3NRHC-40152	1,500 (1,350~1,650)	900	1,220	1,260	
K3NRC-53471	470 (423~517)	300	385	896	70
K3NRHC-53821	820 (738~902)	510	670	1,204	
K3NRHC-53102	1,000 (900~1,100)	625	825	1,386	
K3NRHC-53152	1,500 (1,350~1,650)	900	1,220	1,596	
K3NRTA-15471	470 (423~517)	300	385	148	6
K3NRTB-15471	470 (423~517)	300	385	148	
K3NRTC-15471	470 (423~517)	300	385	148	
K3NRTMA-15471	470 (423~517)	300	385	148	
K3NRTMB-15471	470 (423~517)	300	385	148	

삼상 채널형 / Three phase channel type

Model	Nominal voltage at 1mA(DC) current	Max allowable voltage		Max energy (10/1000 μ s)	Max peak current (8/20 μ s)
	(V)	AC(V)	DC(V)	(Joule)	1Time(kA)
K3NRM-20471	470 (423~517)	300	385	247	10
K3NRHM-20821	820 (738~902)	510	670	344	
K3NRHM-20102	1,000 (900~1,100)	625	825	420	
K3NRHM-20152	1,500 (1,350~1,650)	900	1,220	629	
K3NRC-20471	470 (423~517)	300	385	247	10
K3NRHC-20821	820 (738~902)	510	670	344	
K3NRHC-20102	1,000 (900~1,100)	625	825	420	
K3NRHC-20152	1,500 (1,350~1,650)	900	1,220	629	

써지 킬러 - MC, 릴레이용

SURGE KILLER - MC, relay type

단상형 SINGLE PHASE TYPE

KNRS-10221

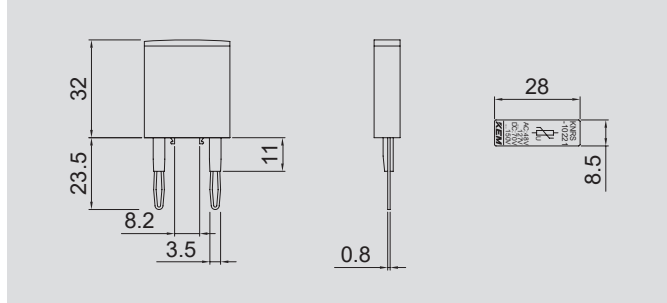

KNR {
15390
15560
15121
15271
15471

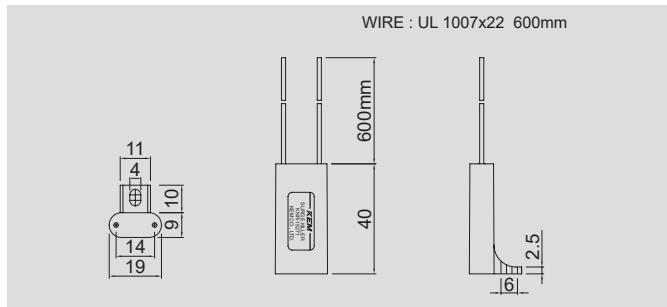

KNR {
20390
20560
20121
20271
20471
KNRH 20821

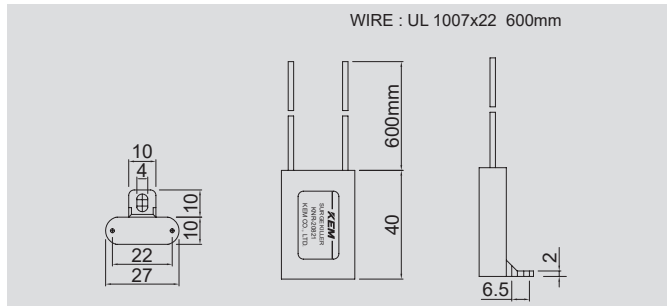

DC용 / ONLY DC

KNRD {
15390
15560
15820
15271
15471

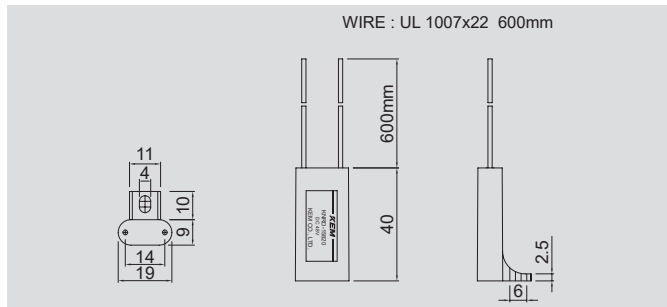

KNR {
10271R
10471R

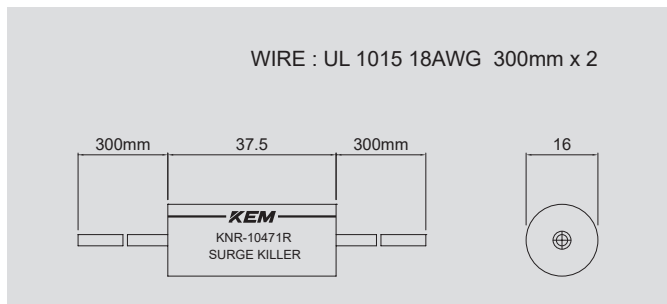

오일 킬러
OIL KILLER

인터페이스 커버
INTERFACE COVER

정류기
POWER CONVERTOR

역결상 계전기
PHASE MONITORING RELAY

풋 스위치
FOOT SWITCH

푸쉬 버튼 스위치
PUSH BUTTON SWITCH

코드 스위치
CODE SWITCH

노브
KNOB

로타리 스위치
ROTARY SWITCH

**써지 보호 장치
SURGE PROTECTIVE DEVICE**

스파크 킬러
SPARK KILLER

LED 인디케이터
LED INDICATOR

노 휴즈 브레카 핸들
N.F.B HANDLE

케이블 그랜드
CABLE GLAND

팬 커버
FAN COVER

힌지/록커/키
HINGE/LOCKER/KEY

로드메타·알피엠메타
LOAD METER·RPM METER

기타 품목
THE OTHER PRODUCTS

써지 킬러 - MC, 릴레이용

SURGE KILLER - MC, relay type

단상형 SINGLE PHASE TYPE

- KNRT { 10121S
- 10271S
- 10471S

DC용 / ONLY DC
KNRDT-10820S

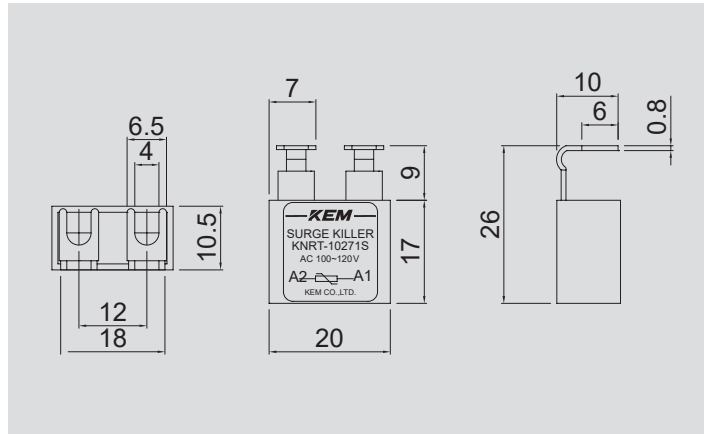

- KNRT { 15390
- 15560
- 15121
- 15271
- 15471

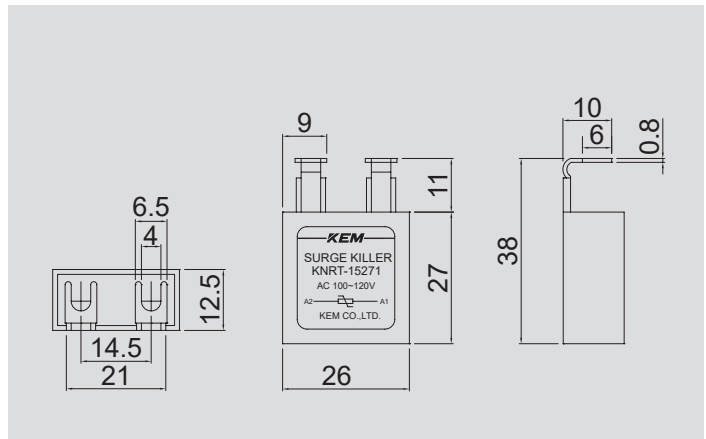

DC용 / ONLY DC

- KNRDT { 15390
- 15560
- 15820
- 15271
- 15471

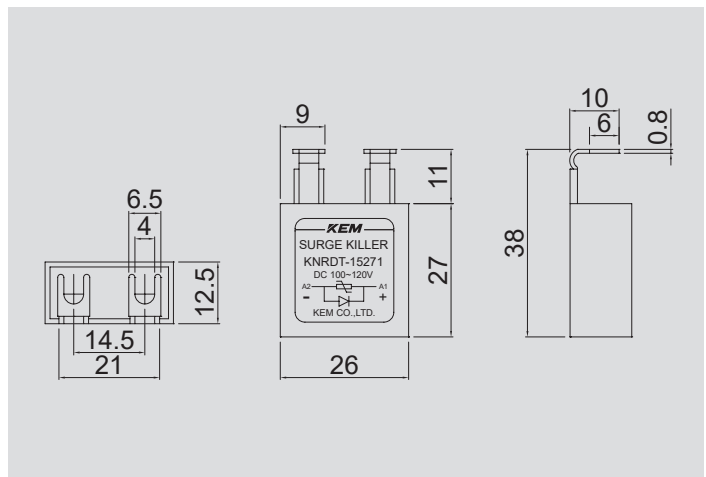

서지 킬러 - MC, 릴레이용

SURGE KILLER - MC, relay type

단상형 SINGLE PHASE TYPE

KNRC { 15271
15471

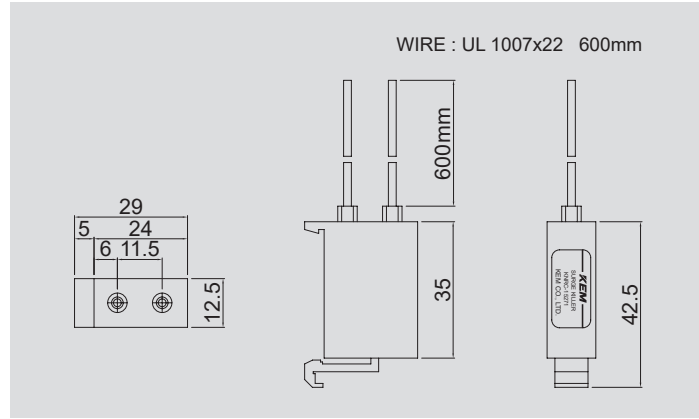

KNRC-20471
KNRHC-20821

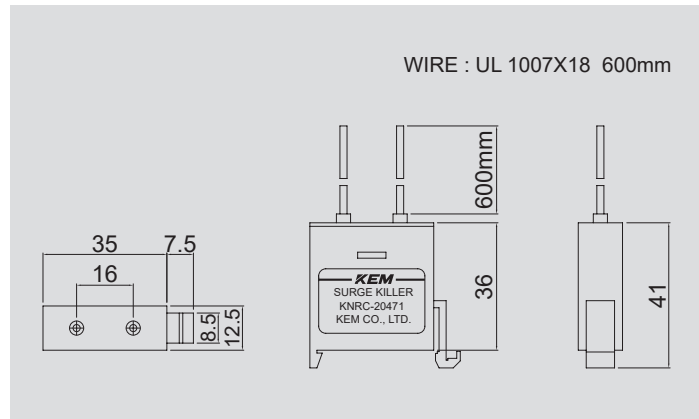

오일 킬러
OIL KILLER

인터페이스 커버
INTERFACE COVER

정류기
POWER CONVERTOR

역결상 계전기
PHASE MONITORING RELAY

풋 스위치
FOOT SWITCH

푸쉬 버튼 스위치
PUSH BUTTON SWITCH

코드 스위치
CODE SWITCH

노브
KNOB

로타리 스위치
ROTARY SWITCH

서지 보호 장치
SURGE PROTECTIVE DEVICE

스파크 킬러
SPARK KILLER

LED 인디케이터
LED INDICATOR

노 휴즈 브레카 핸들
N.F.B HANDLE

케이블 그랜드
CABLE GLAND

팬 커버
FAN COVER

힌지/록커/키
HINGE/LOCKER/KEY

로드메타·알피엠메타
LOAD METER·RPM METER

기타 품목
THE OTHER PRODUCTS

써지 킬러 - MC, 릴레이용

SURGE KILLER - MC, relay type

삼상형 THREE PHASE TYPE

K3NRD-15471

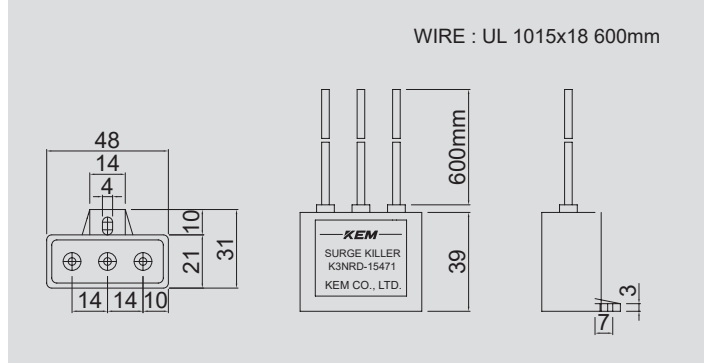

K3NR-20471

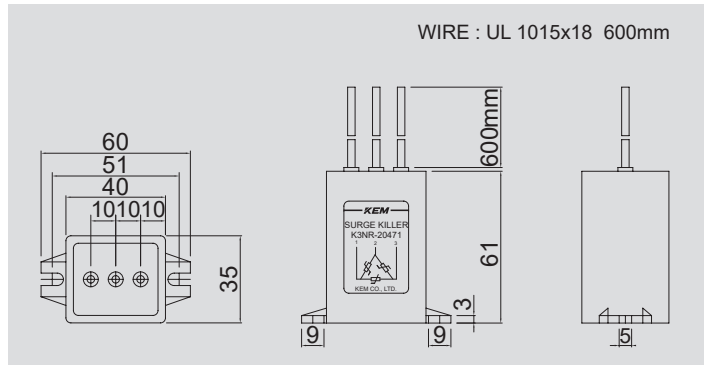

K3NRH { 20821
20102
20152

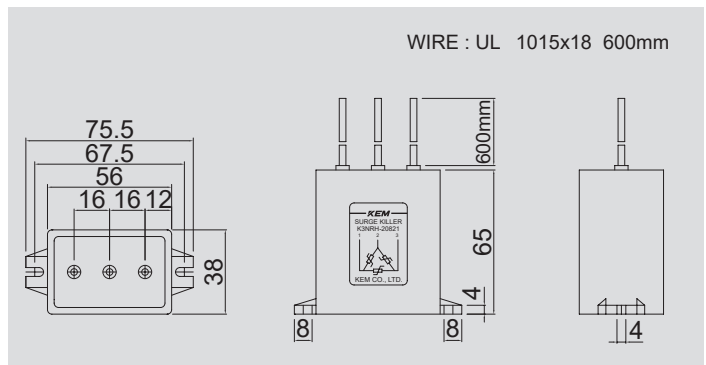

K3NRB { 20471
25471

K3NRHB { 25821
25102
25152

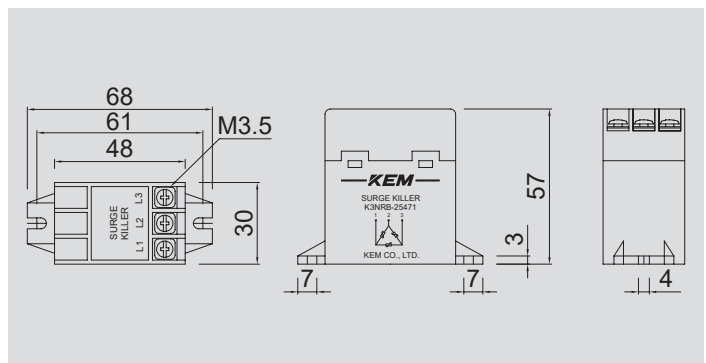

서지 킬러 - MC, 릴레이용

SURGE KILLER - MC, relay type

삼상형 THREE PHASE TYPE

K3NRTA-15471

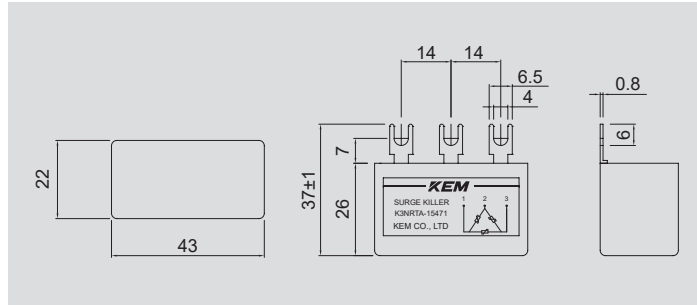

K3NRTB-15471

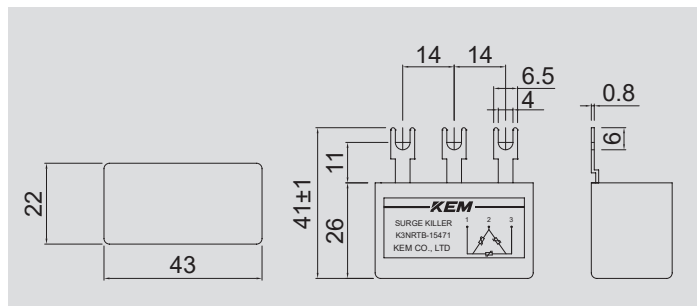

K3NRTC-15471

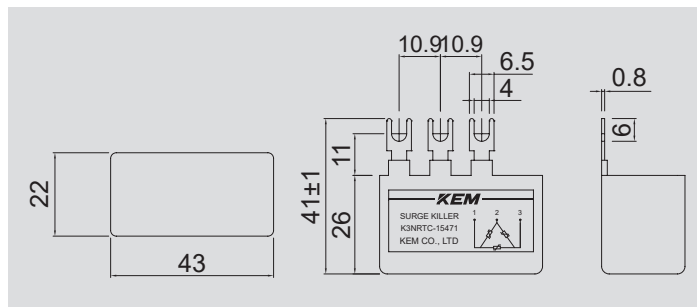

K3NRTMA-15471

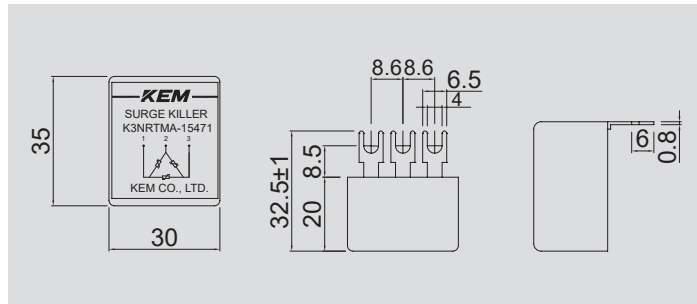

K3NRTMB-15471

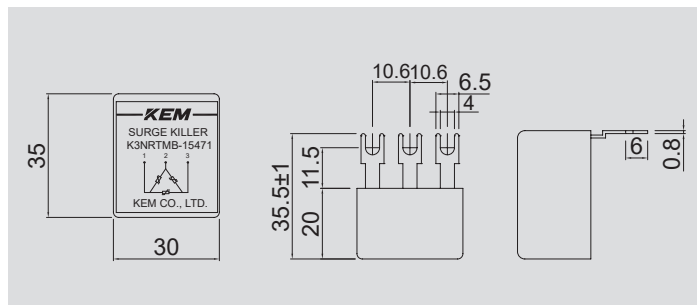

오일 킬러
OIL KILLER

인터페이스 커버
INTERFACE COVER

정류기
POWER CONVERTOR

역결상 계전기
PHASE MONITORING RELAY

풋 스위치
FOOT SWITCH

푸쉬 버튼 스위치
PUSH BUTTON SWITCH

코드 스위치
CODE SWITCH

노브
KNOB

로타리 스위치
ROTARY SWITCH

서지 보호 장치
SURGE PROTECTIVE DEVICE

스파크 킬러
SPARK KILLER

LED 인디케이터
LED INDICATOR

노 휴즈 브레카 핸들
N.F.B HANDLE

케이블 그랜드
CABLE GLAND

팬 커버
FAN COVER

힌지/록커/키
HINGE/LOCKER/KEY

로드메터·알피엠메터
LOAD METER·RPM METER

기타 품목
THE OTHER PRODUCTS

써지 킬러 - MC, 릴레이용

SURGE KILLER - MC, relay type

삼상채널형 THREE PHASE CHANNEL TYPE

K3NRC { 15471
20471

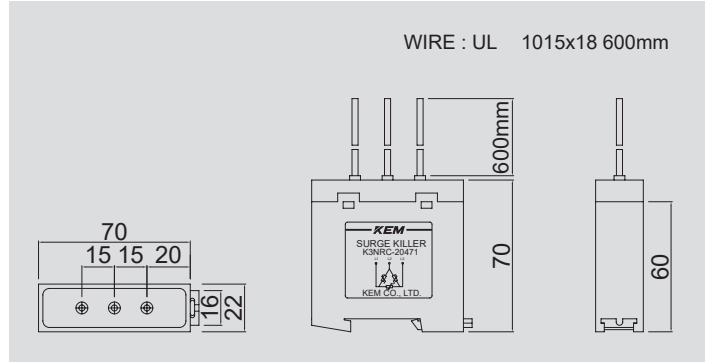

K3NRHC { 20821
20102
20152

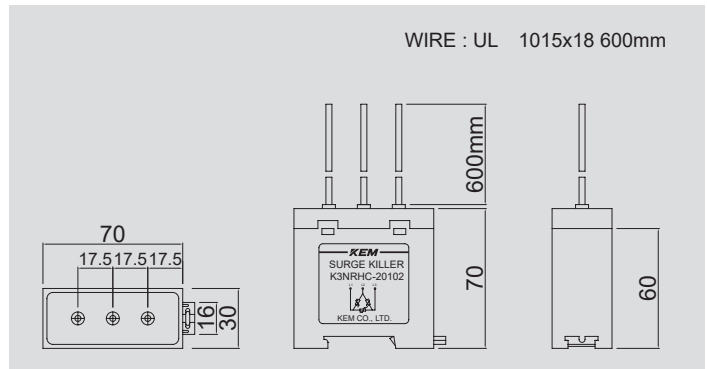

K3NRM-20471

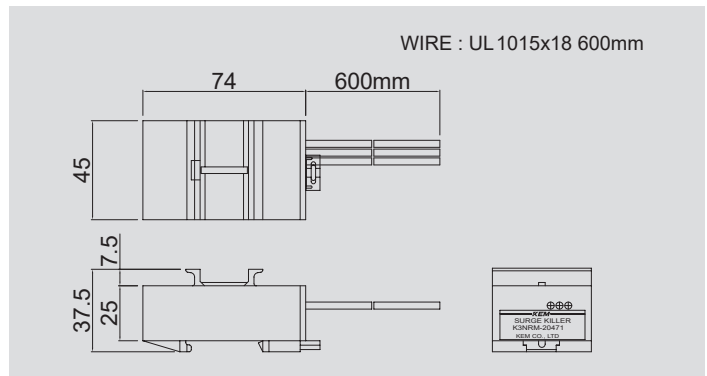
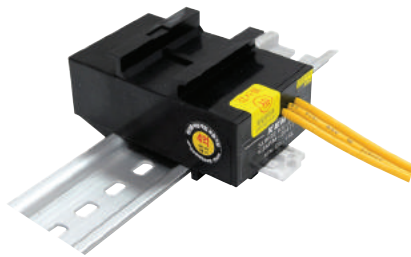

K3NRHM { 20821
20102
20152

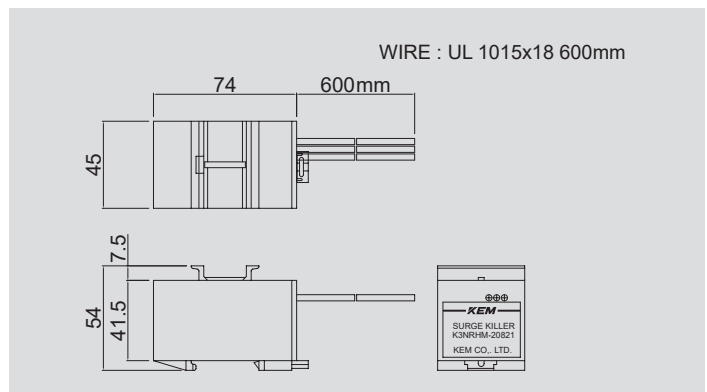

서지 킬러 - MC, 릴레이용

SURGE KILLER - MC, relay type

삼상채널형 THREE PHASE CHANNEL TYPE

K3NRC-32471

K3NRHC {
32821
32102
32152

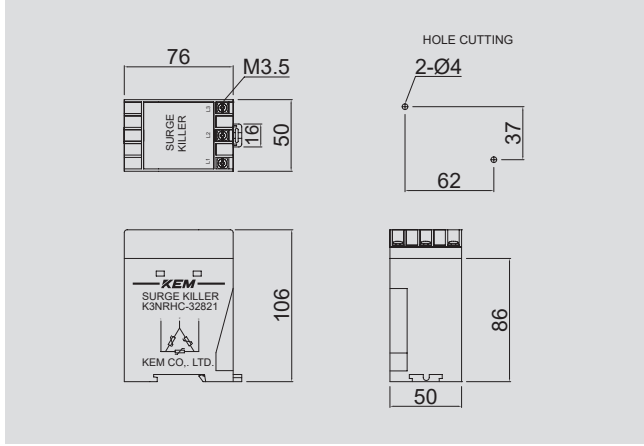

K3NRC-40471

K3NRHC {
40821
40102
40152



K3NRC-53471

K3NRHC {
53821
53102
53152

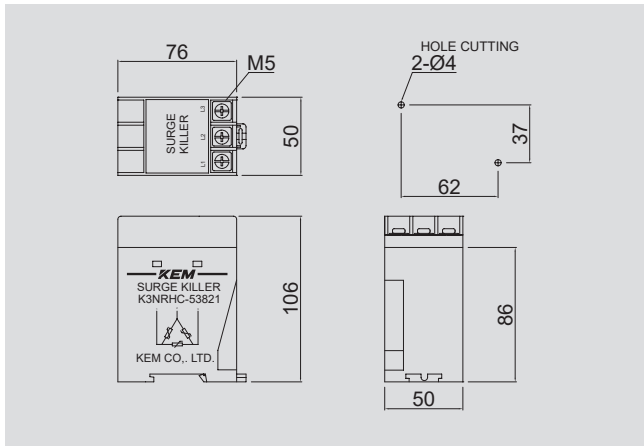

오일 킬러
OIL KILLER

인터페이스 커버
INTERFACE COVER

정류기
POWER CONVERTOR

역결상 계전기
PHASE MONITORING RELAY

풋 스위치
FOOT SWITCH

푸쉬 버튼 스위치
PUSH BUTTON SWITCH

코드 스위치
CODE SWITCH

노브
KNOB

로타리 스위치
ROTARY SWITCH

**서지 보호 장치
SURGE PROTECTIVE DEVICE**

스파크 킬러
SPARK KILLER

LED 인디케이터
LED INDICATOR

노 후즈 브레카 핸들
N.F.B HANDLE

케이블 그랜드
CABLE GLAND

팬 커버
FAN COVER

힌지/록커/키
HINGE/LOCKER/KEY

로드메타·알피엠메타
LOAD METER·RPM METER

기타 품목
THE OTHER PRODUCTS



사용 예 / Usage

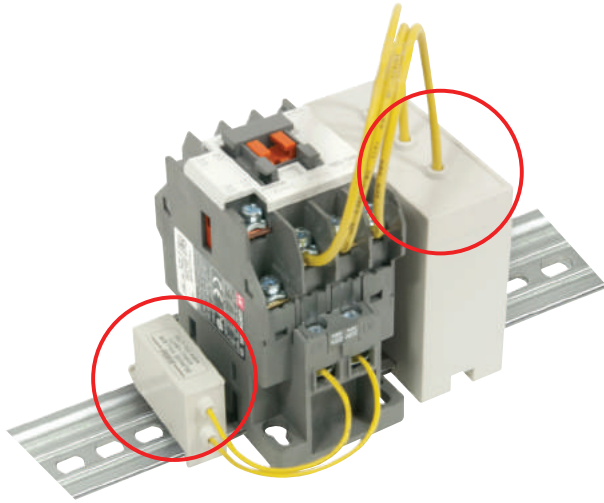

KNRC-15471 / K3NRHC-20102

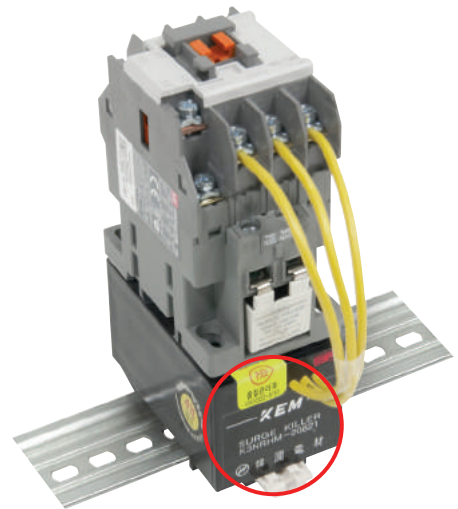

K3NRHM-20821

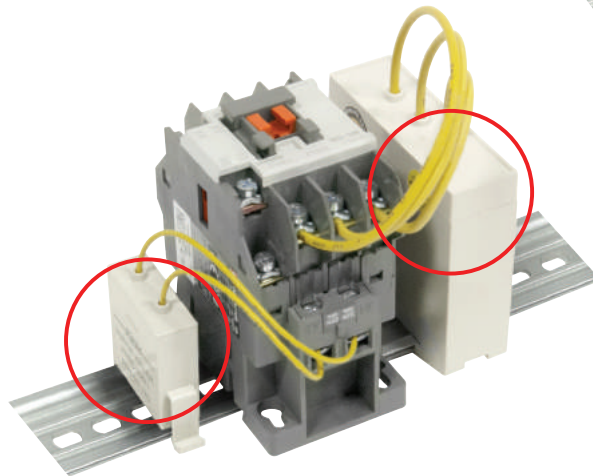

KNRC-20471 / K3NRC-20471

